

# Tensorpack M

## Hybrid ESS

### User Manual

R1.0

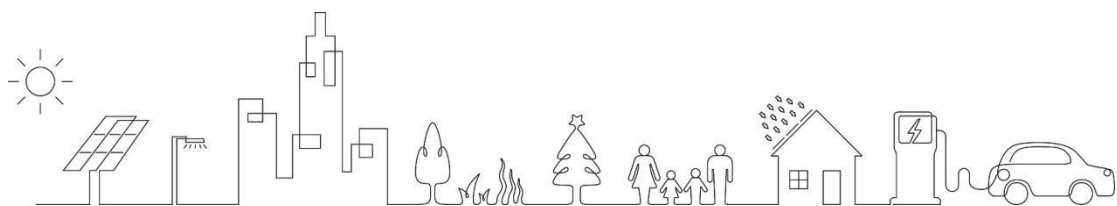

Copyright © Teplore Co., Ltd. 2022. All rights reserved.

Without the written consent of the company, the content of this document may not be extracted, reproduced or disseminated in any form to entities and individuals, either in part or in full.

As Teplore is dedicated to the continuous iteration and update of its products, this document is subject to change owing to product version upgrade or other reasons. This document is used as a guide only, and all statements, information and recommendations contained herein do not constitute any express or implied warranty. Pictures or interfaces provided in this document are for illustration only and may vary depending on product versions or market areas.

For any doubts or problems about this product or this document, please send an email to [info@teplore.com](mailto:info@teplore.com).

**Teplore Co., Ltd.**

**Headquarters (China):**

8th Floor, Building 2, Keya Phase II, 59 Tianyuan West Road, Jiangning  
District, Nanjing

**European Office:**

Haraszti út 48, Budapest, 1239 Hungary

E-mail: [info@teplore.com](mailto:info@teplore.com)

Tel.: +86 2552136163

# Table of Contents

Table of Contents .....	1
Abbreviation and Definition .....	3
1 About This Document .....	4
2 Safety Precautions .....	6
2.1 Statement .....	6
2.2 Label Description .....	7
2.3 Safety Instructions .....	8
3 Product Description .....	16
3.1 Product Introduction .....	16
3.2 Type Designation .....	17
3.3 Appearance .....	18
3.4 Internal Layout .....	19
3.5 Component Description .....	21
3.6 Operating Principle .....	29
4 Transportation and Storage .....	30
4.1 Packaging .....	30
4.2 Transportation Requirements .....	30
4.3 Storage Requirements .....	32
5 Site Requirements .....	34
5.1 Location Requirements .....	34
5.2 Space Requirements .....	34
5.3 Foundation Requirements .....	35
5.4 Forklift Requirements .....	36
6 Installation .....	40

---

6.1 Tools .....	40
6.2 Pre-Installation Check .....	41
6.3 Installing the Battery Cabinet .....	42
6.4 Installing the Inverter .....	43
6.5 Follow-up Procedure .....	45
7 Electrical Connections .....	46
7.1 Grounding the Battery Cabinet .....	46
7.2 Connecting Externally via the Inverter .....	47
7.3 Interconnecting the Battery Cabinet and Inverter .....	47
7.4 Installing the Cable Protective Cover .....	51
8 System Power-On and Power-Off .....	53
8.1 Powering On the System .....	53
8.2 Powering Off the System .....	55
9 Contact Information .....	57
Appendix: Update Record .....	58

---

## Abbreviation and Definition

Abbreviation	Definition
BMU	Battery Management Unit
BCU	Battery Control Unit
BMS	Battery Management System
TMS	Thermal Management System
FFS	Fire Fighting System
LC	Local Controller
TOU	Time of Use
DCM	Demand Charge Management
PCS	Power Conversion System

# 1 About This Document

## Purpose

This document provides the guidelines for Tensorpack M Hybrid Energy Storage System (also referred to as ESS) for the commercial and industrial applications. The content covers the product description, installation, and commissioning.

## Statement

In this manual, "equipment" refers to the products, software, components, spare parts, or services related to this manual; "the company" refers to the manufacturer (producer), seller, or service provider of the equipment; "customer" refers to the entity that transports, stores, installs, operates, or maintains the equipment.

## Symbol Conventions

To alert readers or users about the precautions that should be observed during installation, operation, and maintenance to ensure personal and equipment safety, this document uses the following safety symbols:

### Danger

Indicates a high potential hazard that, if not avoided, will result in death or serious injury.

### Warning

Indicates a moderate potential hazard that, if not avoided, may result in

death or serious injury.

### Caution

Indicates a low potential hazard that, if not avoided, may result in minor or moderate injury.

### Notice

Indicates a potential hazard that, if not avoided, may result in equipment malfunction or property damage.

### Note

Provides supplementary explanation or key details in the main text. It is not a safety alert and does not contain information related to personal injury, equipment damage, or environmental hazards.

## 2 Safety Precautions

### 2.1 Statement

Before installing or operating the equipment, please read all safety instructions carefully. It is mandatory to strictly adhere to all safety precautions, safety markings on the equipment, applicable laws, regulations, standards, and norms.

In this manual, the terms "danger," "warning," "caution," and "note" are not limited to all safety matters that should be followed. Customers must also comply with relevant international, national, or regional standards and industry practices. The equipment should be used in an environment that meets the requirements. Incorrect operation can lead to product damage and property loss, and even cause personal injury, for which the company is not liable.



The company is not responsible for any of the following situations or their consequences:

- Equipment damage caused by force majeure such as floods, flash floods, typhoons, earthquakes, tsunamis, lightning, volcanic eruptions, war conflicts, government bans, strikes, etc.;
- Damage caused by transportation by the customer or a third party authorized by the customer;
- Damage caused by failure to comply with the requirements of this manual;
- Installation and operation that do not comply with relevant international, national, or regional standards;

- Failure to observe the safety precautions and operating instructions specified in this manual;
- Failure to follow the safety markings indicated on the equipment;
- Installation and use of the equipment by unqualified personnel;
- Customer-provided non-standard tools that do not meet relevant standards;
- Damage caused by the customer’s intentional acts, gross negligence, operational violations, or reasons not attributable to the company.

## 2.2 Label Description

Labels on system includes essential information for safely operating the product. It is strictly forbidden to intentionally damage or remove these labels. If the labels become blurred, damaged, or lost, they must be replaced immediately. The machine identification includes:

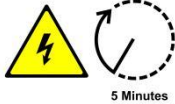
Label	Description
	Indicates high voltage danger; touching may result in an electric shock hazard.
	Advises caution for safety; avoid unnecessary contact to prevent personal injury.
	Indicates that this is a protective ground (PE) and must be securely grounded to ensure personal safety.
	Indicates the presence of lethal high voltage. After disconnecting the equipment from the external power source, wait 5 minutes before touching any internal conductive components.



Indicates that the manual should be read before performing any operations on the product.

Table 2-1 Label description

## 2.3 Safety Instructions

### 2.3.1 General Safety

#### Danger

- Touching the power grid or terminals and contacts connected to the ESS may cause fatal electric shocks!
- There is lethal high voltage inside the product; heed and follow the warning signs on the product!
- Damaged equipment or product malfunctions may cause electric shocks or fires.

### 2.3.2 Personal Safety

#### Danger

- During equipment operation, unauthorized or incorrect operations can cause fires, electric shocks, or explosions, leading to product damage, property loss, and even personal injuries.
- During work, it is strictly forbidden to wear various conductive objects such as watches and necklaces to avoid electric shock injuries.
- During work, it is mandatory to use regulatory standard specialized insulated tools to avoid electric shock injuries or short circuits.

## General Requirements

- If faults that may cause personal injury or equipment damage are discovered during work, stop the operation immediately and, after confirmation by a responsible person, take effective protective measures.
- Before powering on the equipment, ensure it is fully installed and checked by professionals.
- It is forbidden to touch or indirectly contact powered equipment; voltage at the contact points should be measured before touch to ensure there is no risk of electric shock.
- Do not touch operational fans with fingers or tools to prevent personal injury or equipment damage.
- In case of a fire, immediately evacuate the building or equipment area and press the fire alarm or call the fire department.

## **Personnel Requirements**

- Personnel performing electrical operations on this product must have professional training and relevant operation certificates.
- Operators should have a certain level of electronic, electrical wiring, and mechanical expertise, and be fully familiar with the internal electrical principles of the product.
- Operators should be familiar with various safety precautions and relevant standards of their country/region.
- Only qualified professionals or trained personnel are allowed to install, operate, and maintain the equipment.
- Only qualified professionals are allowed to remove safety facilities and service equipment.

- Installation or operation personnel should have the ability to respond to emergencies or unexpected situations that may arise during installation or trial operation.
- Personnel involved in special scenarios such as electrical operations, working at heights, or operating special equipment must have the special operation qualifications required by their local country/region.
- Except for personnel operating the equipment, other individuals should not approach the equipment.

### 2.3.3 Electrical Safety

#### Danger

- Before making electrical connections, ensure the equipment is undamaged, as damage may cause electric shocks or fires.
- Both the battery side and grid side may produce voltage; always use a standard voltmeter to ensure no voltage before touching.
- Disconnect the power source of the ESS; the battery will not immediately lose power, wait 10 minutes to ensure the equipment is completely de-energized before operating.
- Prevent foreign objects from entering the equipment during work as they may cause short circuits, damage, power supply derating, or personal injuries.

#### Warning

- Ensure the system is reliably grounded before performing electrical

installations or connections; otherwise, there may be a risk of electric shock when touching the product.

- Do not damage the grounding conductor.

## General Requirements

- Installation, operation, and maintenance must be performed according to the manual's sequence; do not arbitrarily change the installation order, modify or alter the equipment.
- Permission from local electrical authorities is required for grid-connected operation.
- Erect warning signs or set up safety barriers near the equipment, and strictly prohibit non-working personnel from entering.
- Disconnect the equipment itself and the upstream and downstream switches before installing or removing power cables.
- If liquid enters the equipment, immediately turn off the power and do not continue using it.
- Before operating the equipment, carefully check that the tools used meet the requirements and are registered; after the operation, collect them back to prevent them from being left inside the equipment.

## Cable Requirements

- Before installing power cables, ensure the cable labels are correct and the cable terminals have been insulated.
- The selection, installation, and routing of cables must comply with local laws, regulations, and standards.

- During the laying of power cables, avoid looping or twisting. If the power cable is found to be too short, replace it; do not make joints or soldering points in the power cable.
- All cables must be securely connected, well-insulated, and of appropriate specifications.

### Grounding Requirements

- The equipment grounding impedance should meet local electrical standards.
- The equipment should be permanently connected to protective ground. Before operating the equipment, check the electrical connections to ensure the equipment is reliably grounded.
- Do not operate the equipment without installing a grounding conductor.

### 2.3.4 Environmental Requirements

#### Danger

It is strictly forbidden to pile flammable and explosive materials around the installation site.

#### Warning

- Install the equipment away from liquids, and strictly prohibit installation under locations such as water pipes and air vents where condensation can occur.
- Do not install under air conditioning vents, ventilation ducts, or

windows where leakage is possible to prevent liquids from entering the equipment and causing faults or short circuits.

- The equipment should be installed in a clean, neat, and well-ventilated area; do not pile miscellaneous items within a 2-meter radius.
- Do not install the equipment in environments with radioactive radiation, high salinity, strong vibration or magnetic fields, or where fungi can easily grow.

#### Notice

Avoid opening the maintenance door of the ESS for maintenance and inspection under adverse conditions with air humidity >95% or during rainy and humid weather.

- Moisture intrusion can damage the product. To ensure the normal and safe operation of the system, pay attention to environmental humidity during routine maintenance and inspection.
- The installation site should meet the requirements for equipment ventilation and personnel evacuation.
- Before installing the equipment, ensure the installation surface is solid, free of adverse geological conditions, and meets the load-bearing requirements of the equipment.
- Before maintenance, clean the accumulated water, ice, snow, or other debris on top.
- After installing the equipment, clear empty packaging materials from the area.

## 2.3.5 Operation and Maintenance Safety

### Warning

- During routine operation, ensure the equipment cabinet doors are closed and locked, and the keys are removed and kept by a designated person to prevent unauthorized access and accidents.
- Except for necessary checks and maintenance, do not open the cabinet doors to prevent moisture from entering the equipment and causing short circuits and damage.
- Except for personnel operating the equipment, other individuals should not approach the equipment.
- When performing maintenance and repairs, personal protective equipment must be equipped.

### Notice

- Do not spray any devices inside or outside the equipment.
- Do not clean the equipment with cleaning agents or expose it to corrosive chemicals.

### General Requirements

- Personnel operating the equipment must be professionals and trained personnel.
- Ensure that the internal devices and systems of the battery system are completely de-energized.
- Erect clear warning signs at the disconnection points to prevent dangerous accidents caused by misoperation.

- Set up warning signs or safety barriers in the operation area.
- During checks or maintenance, ensure at least two personnel are present.
- Wear protective equipment, including safety goggles, insulated gloves, insulated shoes, and safety helmets, as necessary to ensure the safety of personnel and equipment.
- After operations, lock the maintenance door of the ESS and securely store the keys.

## 3 Product Description

### 3.1 Product Introduction

The **Tensorpack M Hybrid Energy Storage System (ESS)** is an all-in-one solar-plus-storage solution designed for commercial and industrial applications. It integrates a battery cabinet with a hybrid inverter to support key features including Time-of-Use (TOU) , Demand Charge Management (DCM), PV consumption, capacity expansion, ancillary services, and emergency backup.

As a highly integrated system, Tensorpack M enables efficient solar energy storage and bidirectional energy conversion through coordination between the battery system and the hybrid inverter.

The system comprises the following core components:

- Battery pack
- Hybrid inverter
- High-voltage (HV) control box
- Thermal Management System (TMS)
- Fire Fighting System (FFS)
- Battery Management System (BMS)

#### Features of Tensorpack M Hybrid ESS

- TOU (Time of Use)

The LC manages ESS charging or discharging according to tariff structures and load profiles. The system charges during off-peak

periods and discharges during peak periods, optimizing electricity cost savings.

- DCM (Demand Charge Management)

By regulating ESS power output based on transformer load at the grid connection point, the system prevents power demand from exceeding the set demand. This maintains consumption within demand levels and improves economic efficiency.

- PV Consumption

When PV generation exceeds local load demand, excess energy is stored in the ESS batteries to prevent grid feed-in. The LC automatically reduces discharge power when load decreases, ensuring no energy export to the grid.

- Capacity Expansion

Integrated with charging station monitoring systems, the LC coordinates transformer load, charging power, and ESS operation to maintain total power consumption within the transformer's safe operating capacity.

- Ancillary Services

Through connectivity with grid operator dispatch platforms, the system enables behind-the-meter services including demand response, peak shaving, and frequency regulation.

## 3.2 Type Designation

This document covers the product model M241-50.

1
2
3

Figure 3-1 Type designation

No.	Def.	Description
1	Serial Product	M: Tensorpack M Hybrid ESS
2	Battery System Capacity	120: Rated Capacity 120kWh
3	Power Rating	50: The power rating of the ESS is 50kW.

### 3.3 Appearance

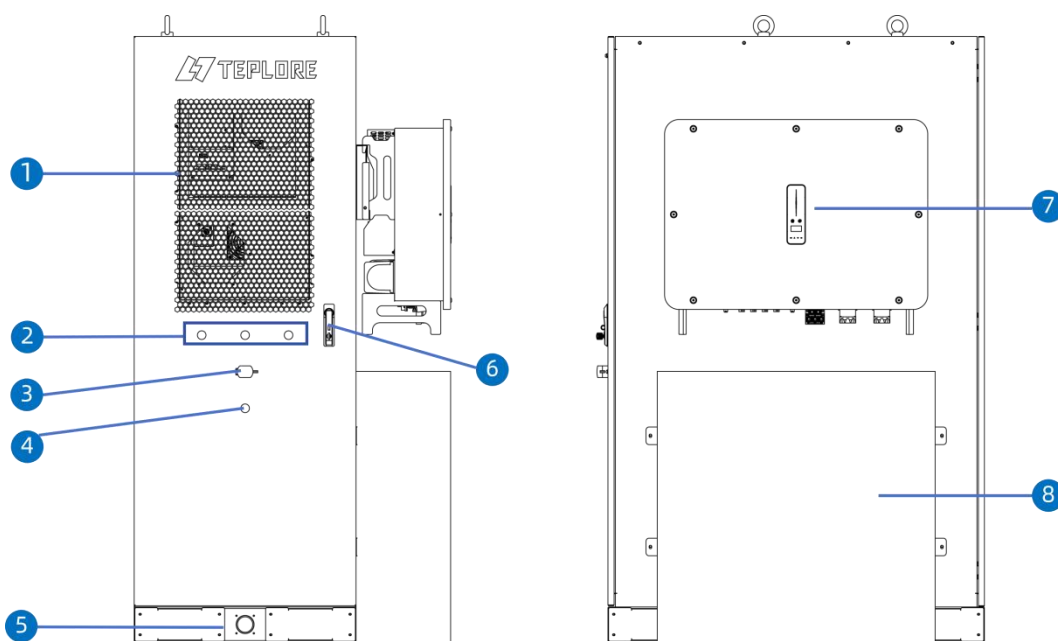

Figure 3-2 Appearance

No.	Component
1	Thermal Management System (TMS)
2	Device Status Indicators*
3	Emergency Switch
4	On-Off Switch (Rotary Type)

5	Fire Suppression Interface
6	Door Lock
7	Hybrid Inverter
8	Cable Protective Cover

Table 2-2 Appearance Description

\*Device Status Indicators indicate three statuses: Standby, Run and Fault.

Figure 3-3 demonstrates the dimensions of the Tensorpack M ESS (Unit:mm).

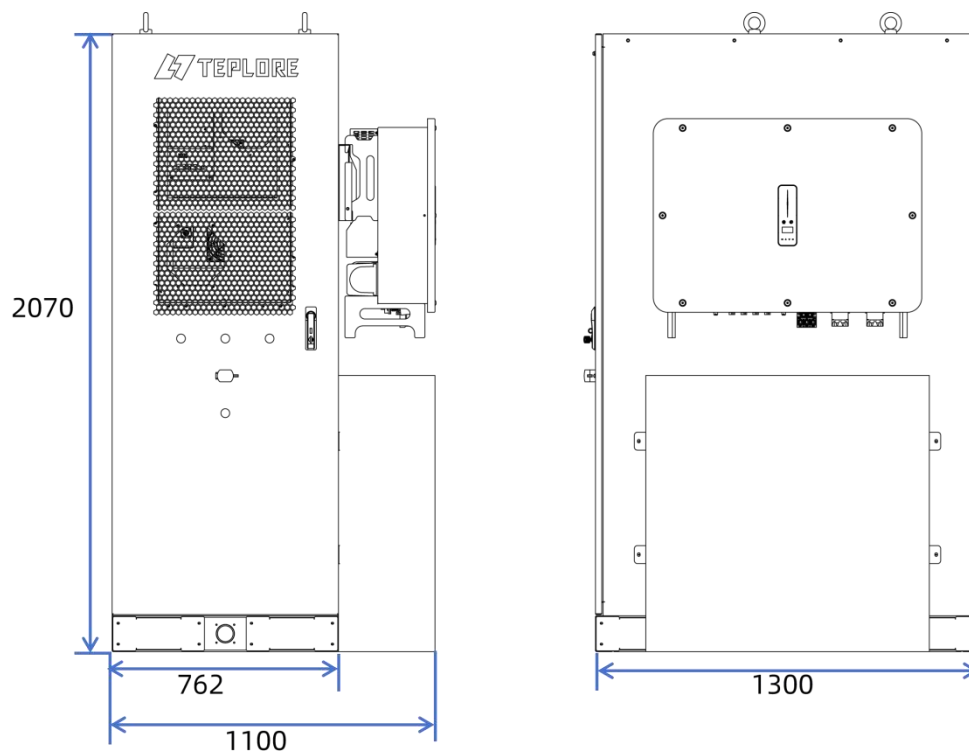

### 3.4 Internal Layout

The internal layout of the battery cabinet is shown in Figure 3-3.

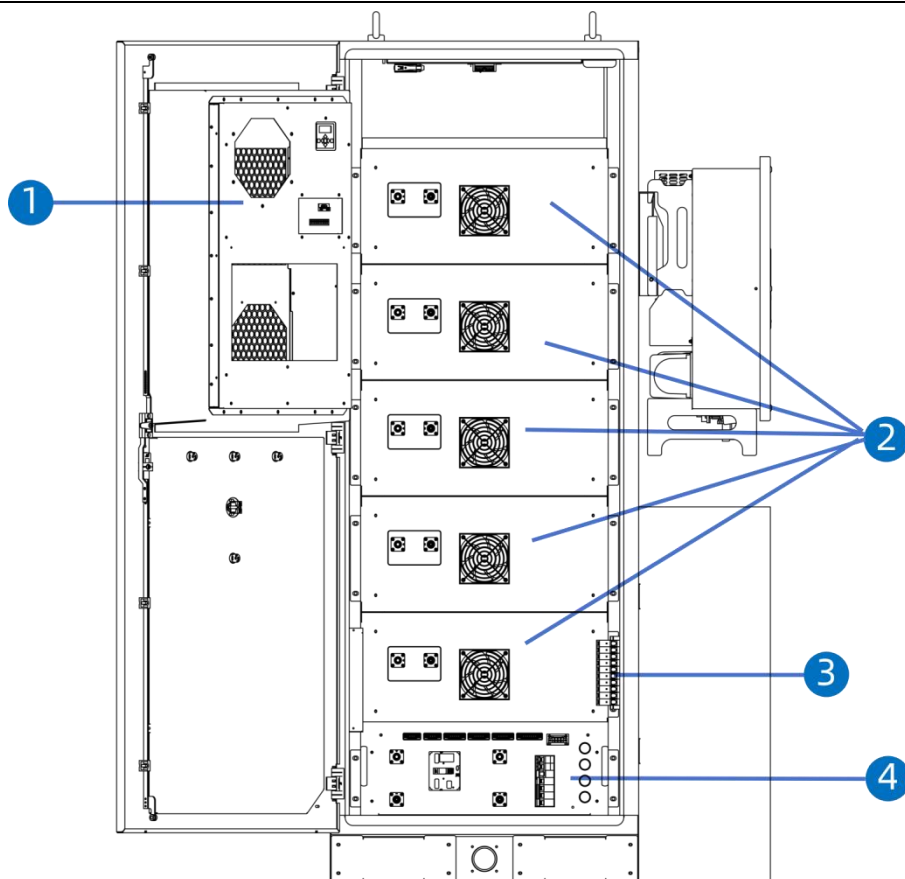

Figure 3-3 Internal layout of the battery system

No	Name
1	TMS
2	Battery Pack
3	Terminal Block
4	HV Control Box

Table 3-1 Components of the battery system

## 3.5 Component Description

### 3.5.1 Battery Pack

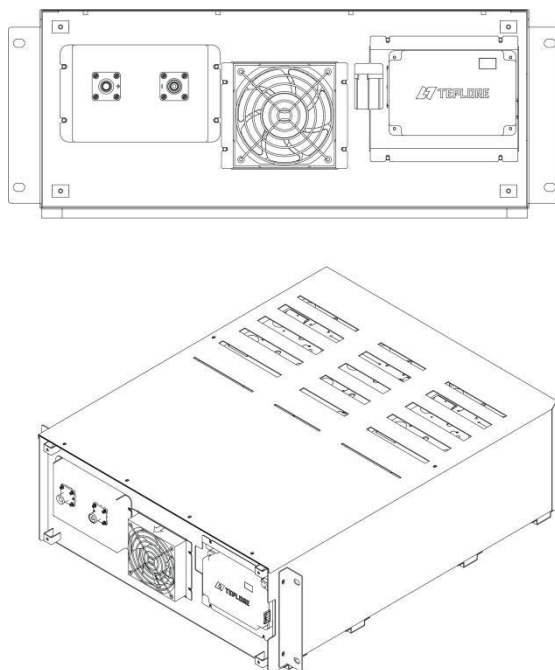

Figure 3-4 Battery pack appearance

Parameter	Specification
Dimension (W × D × H)	666mm x 762mm x 249mm
Weight	170kg
Rated Capacity	24.1kWh
C-Rate	≤ 0.5P
Configuration	1P24S
Core Components	24S Cells, BMU, Pack Fan

Table 3-2 Battery pack technical specifications

### 3.5.2 BMS

The Battery Management System (BMS) is the intelligent core responsible for ensuring the safety, reliability, and optimal performance of the battery pack. This hierarchical system primarily comprises the Battery Management Unit (BMU) and the Battery Control Unit (BCU).

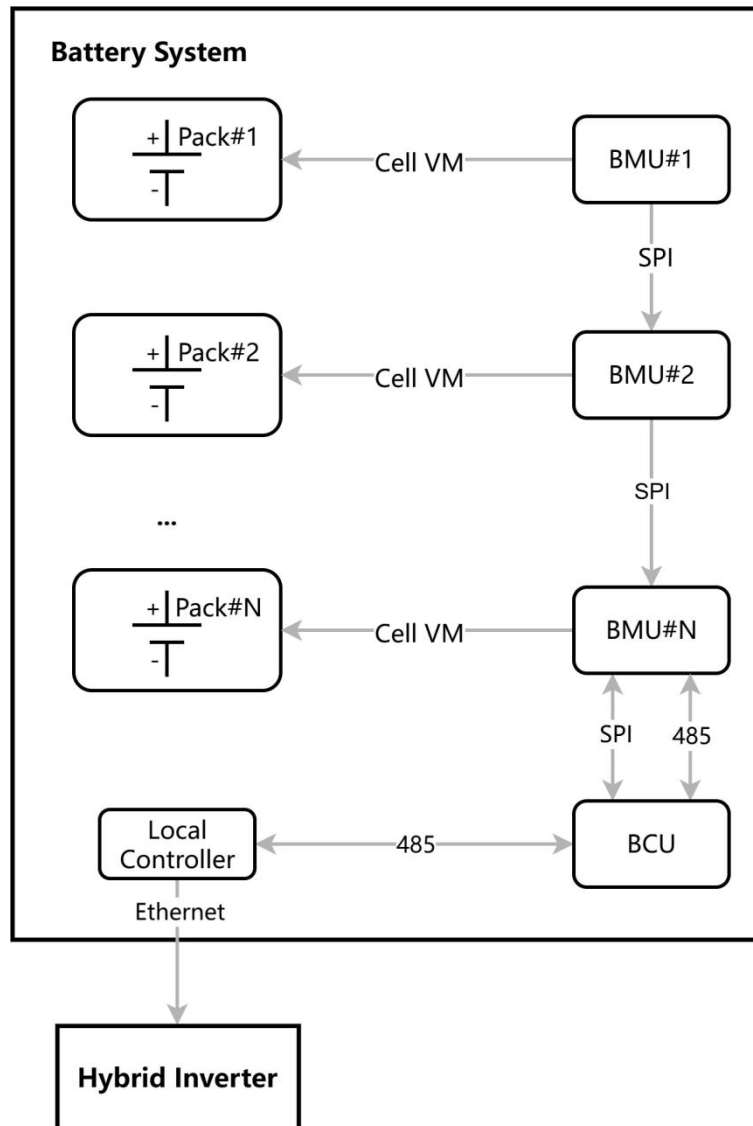

Figure 3-5 BMS topology

## BMU

The BMU is a critical component of the energy storage BMS, ensuring safe operation and extended battery life through precise real-time monitoring of individual cell voltage and temperature.

### Key Features:

- Accurately monitors individual cell voltage and temperature across multiple battery chemistries.

- Supports passive cell balancing to maintain pack consistency and extend battery life.
- Features robust daisy-chain communication for reliable data transmission to the master controller.
- Built with self-diagnostic capabilities and high-safety design.

## **BCU**

The BCU is the central control unit of the BMS, managing battery state estimation, charge/discharge, balancing, and safety functions by communicating with BMUs and external systems like PCS and EMS.

### **Key Features:**

- Designed with high reliability and multi-layer safety protection to ensure safe battery operation under all conditions, in compliance with industry standards.
- Provides accurate battery monitoring and dependable SOC indication for efficient system operation and energy management.
- Built to withstand electrically noisy environments in storage systems, ensuring stable communication and signal integrity.
- Supports flexible system expansion and remote configuration updates via standard CAN interface, simplifying deployment and maintenance.

### **3.5.3 HV Control Box**

The High-Voltage (HV) Control Box integrates a pre-charge circuit, DC contactor, DC circuit breaker, auxiliary power supply, and the System Monitoring Unit (SMU) to manage and protect the HV DC loop.

In the event of a serious system fault, the integrated DC circuit breaker disconnects the circuit to ensure battery system safety and the proper operation of control circuits.

Note: Conditional short-circuit current (I<sub>cc</sub>) = 6kA

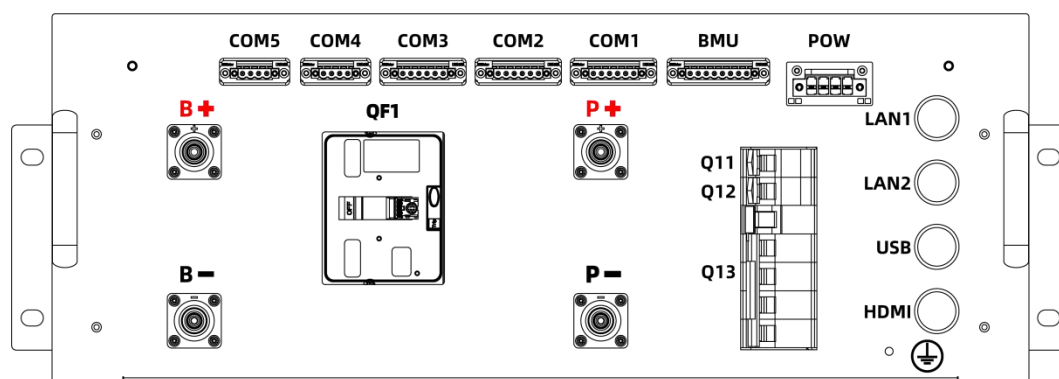

Figure 3-6 HV Control Box appearance

Terminal	Terminal Declaration
P+	PCS input positive
P-	PCS input negative
B+	Battery side positive
B-	Battery side positive
BMU	BMU communication interface
POW	Auxiliary power input and air conditioner power output
COM1	Air conditioner communication
COM2	Fire protection system communication
COM3	General signal communication
COM4	Water leakage and door access monitoring input
COM5	Spare communication port
LAN1	Ethernet for local network
LAN2	Ethernet for inverter communication

Terminal	Terminal Declaration
HDMI	High-definition multimedia interface
USB	Universal serial bus

Table 3-3 Terminal Description

### 3.5.4 TMS

The Thermal Management System (TMS) consists of industrial air conditioners, water immersion sensors, and door magnets inside the cabinet.

#### Industrial Air Conditioner:

Each side of the front door panel of the system is equipped with an industrial air conditioner. These units provide intelligent temperature control within the system, enabling preheating in extremely cold environments and cooling when the ambient temperature is high. The parameters of the industrial air conditioner are shown in Table 3-4.

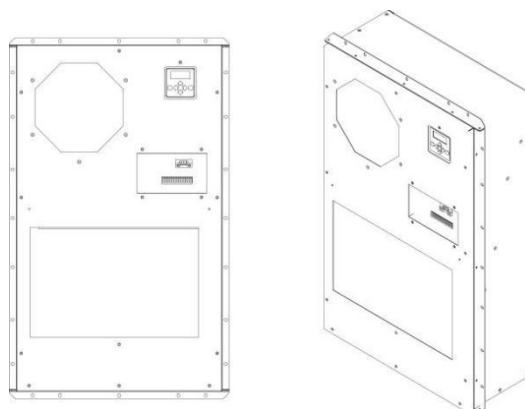

Figure 3-7 Industrial air conditioner appearance

Parameter	Specification
Configuration Quantity	2 Sets
Operating Temperature	-40°C ~ +55°C
Refrigerant	R134a
Cooling Capacity L35	2000W

Parameter	Specification
Heating Capacity	1000W
Internal Circulation Airflow	650m <sup>3</sup> /h
Power Supply Range	220V±15%, 50/60Hz

Table 3-4 Industrial air conditioner specification

## Water Immersion Sensors

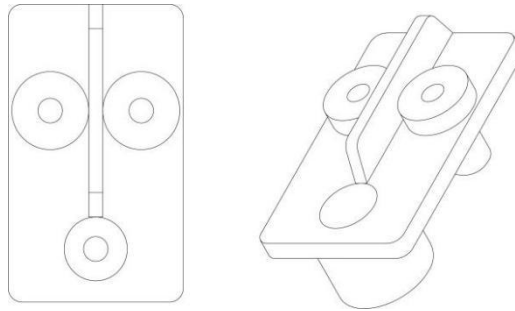

Figure 3-8 Water immersion sensors appearance

Parameter	Specification
Power Supply	24Vdc±10%
Operating Current	<15mA in dry state; <50mA in water alarm state
Operating Humidity	0 ~ 100% RH (no condensation)
Alarm Threshold Range	50kΩ±10kΩ (hysteresis value ≥5kΩ)

Table 3-5 Water immersion sensors specification

### 3.5.5 FFS

The Fire Fighting System (FFS) consists of a composite gas sensor, an aerosol unit, and pressure relief valves.

A composite gas sensor (monitoring CO, smoke, temperature, and VOC) is installed at the top of the internal space to detect the internal environment. Upon detection of thermal runaway, the aerosol fire suppression unit is triggered.

One 300g aerosol unit is installed inside the cabinet to provide total flooding fire protection within the enclosed space.

Pressure relief valves are installed on both sides of the cabinet top to maintain internal pressure stability, and prevent potential explosion hazards caused by excessive pressure during thermal runaway events.

## Composite Gas Sensor

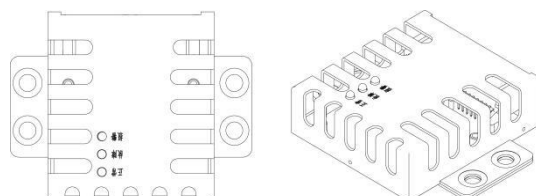

Figure 3-9 Composite gas sensor appearance

Parameter	Specification	
Operating Humidity	<95%RH	
Operating Pressure	55~106kPa	
Detection Range	Smoke, Temperature, Carbon Monoxide, Electrolyte Gas	
Measurement Range	0 ~ 5000ppm	-40°C ~ +125°C
Measurement Accuracy	<±10ppm	±0.5°C
Data Collection Interval	1s	

Table 2-11 Composite gas sensor specification

## Aerosol

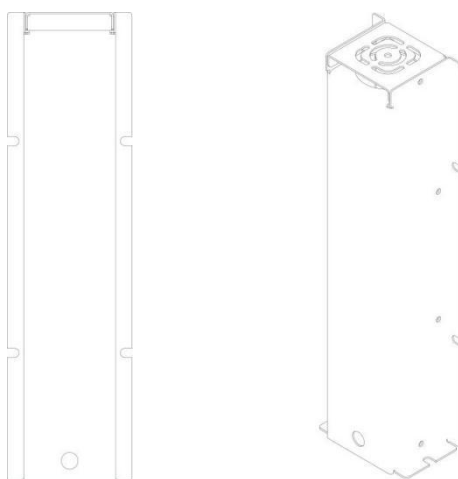

Figure 3-10 Aerosol appearance

Parameter	Specification
Activation Method	Electric Start & Thermal Start

Thermal Start Temperature	≥170°C
Safe Current	≤200mA
Activation Current	≥700mA
Fire Extinguishing Efficiency	100g/m <sup>3</sup> ~ 130g/m <sup>3</sup>
Protection Space	3m <sup>3</sup>

Table 3-6 Aerosol specification

## Pressure Relief Valve

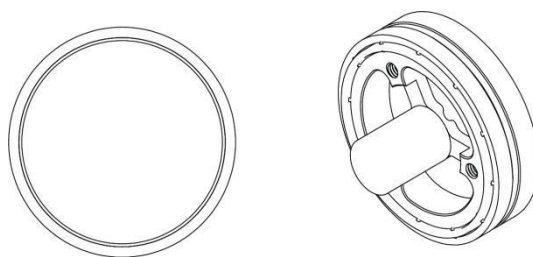

Figure 3-11 Pressure relief valve appearance

Parameter	Specification
IP Rating	IP68
Diaphragm Air Permeability	≥1L/min@1.5kPa
Burst Pressure	4±1kPa
Exhaust Area (maximum opening)	600mm <sup>2</sup>
Temperature Resistance	-40°C ~ +125°C

Table 2-13 Pressure relief valve specification

### 3.5.6 Hybrid Inverter

The hybrid inverter (hereinafter referred to as the inverter) is installed at the upper section of the right side panel. To learn more about the inverter, refer to the user manual of the inverter.

### 3.6 Operating Principle

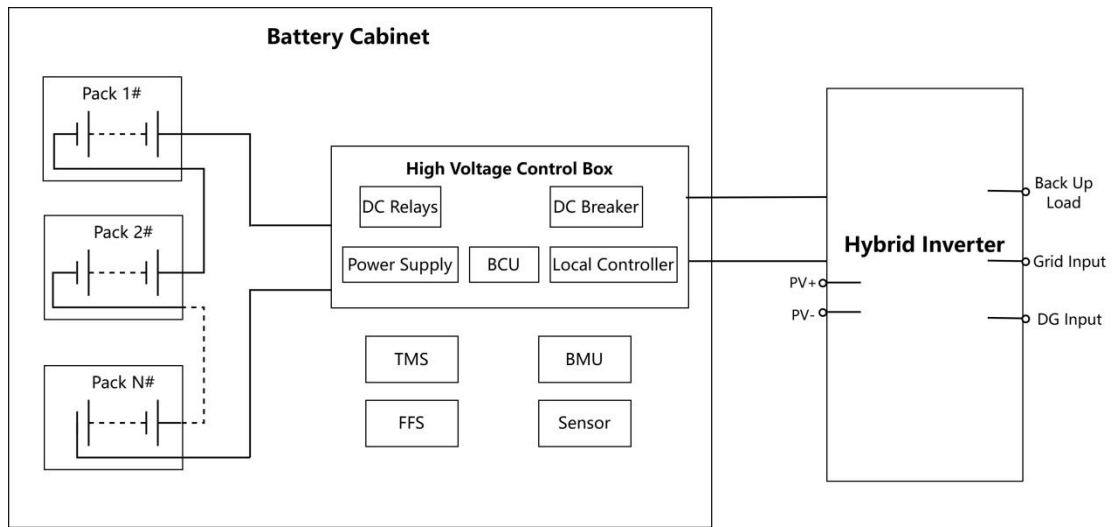

Figure 3-12 Tensorpack M Hybrid ESS block diagram

## 4 Transportation and Storage

### 4.1 Packaging

The battery system is secured on a wooden pallet with fasteners for transportation and storage. The cabinet body is wrapped with multiple layers of film and supported by foam corner protectors. Detailed packaging is shown in Figure 4-1.

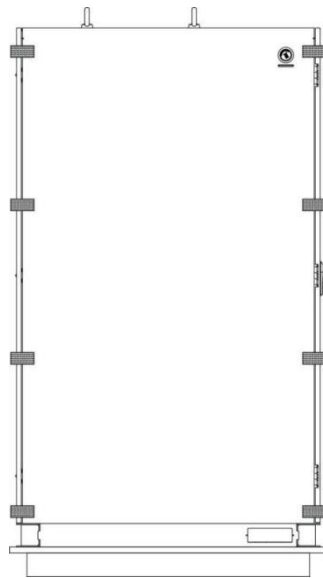

Figure 4-1 Packaging

### 4.2 Transportation Requirements

#### Warnings

- Any rough handling may cause the equipment to short circuit, damage, leak, crack, catch fire, or explode.
- Before transportation, ensure that the equipment packaging is intact and undamaged, with no unusual smells, leaks, smoke, or fire. If any of these conditions are present, do not transport.

**Note**

Set up warning signs or tape in the moving area to prevent unauthorized personnel from entering and ensure safe transportation.

During transportation and storage, the tilt angle of the cabinet with packaging should meet the requirements shown in the diagram and be limited to  $\alpha \leq 15^\circ$ ; after removing the packaging, the tilt angle of the cabinet should be limited to  $\alpha \leq 10^\circ$ .

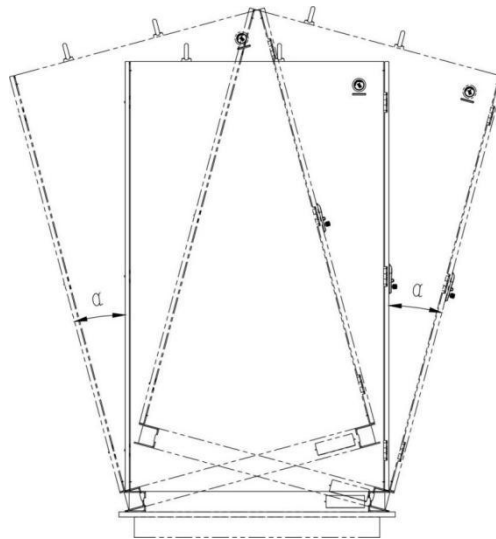

Figure 4-2 Cabinet Tilt Angle

- The transportation service provider must be qualified for transporting hazardous materials. Open-top vehicles are strictly prohibited.
- The equipment can be directly shipped to the site, meeting the requirements of car and ship transportation. Sea or road transport with good road conditions is preferred, while rail and air transport are not supported, following international dangerous goods transport regulations.

- Ensure all cabinet doors are securely locked before moving the equipment to prevent them from loosening or opening during transport.
- Choose appropriate forklifts or hoisting tools based on site conditions, ensuring they have sufficient load capacity, arm length, and turning radius.
- It is prohibited to transport the battery Pack alone, and do not disassemble the battery system during transportation.

### **4.3 Storage Requirements**

- During storage, maintain relevant proof that meets product storage requirements, including temperature and humidity log data, storage environment photos, and inspection reports.
- Long-term storage of the battery system is not recommended to avoid capacity loss. If long-term storage of lithium batteries is necessary, it should not exceed six months.
- For equipment stored for more than six months, perform a charge-discharge cycle to bring the system SOC to 30%-40%.
- Store in a clean and dry place, ensuring the cabinet doors are locked, the storage ground is flat, and away from rain and standing water to prevent dust and moisture corrosion.
- Do not store in environments containing corrosive or flammable gases, and avoid tilting or inverting the storage.
- During long-term storage, do not remove packaging or stack storage. Ensure the storage ground is flat, and the environment's temperature and humidity are within the specified range.

- The storage environment temperature should be between -30°C and +60°C, and relative humidity should be maintained at 5% RH to 95% RH.
- For long-term stored equipment, perform a visual inspection before installation, and conduct tests by professionals after power-up and start-up.
- Pay attention to adverse environmental conditions such as sudden cold, sudden heat, and impacts to avoid damaging the equipment.

## 5 Site Requirements

### 5.1 Location Requirements

When choosing a suitable location for installing the battery system, consider the characteristics of the climatic environment and geological conditions to ensure the system operates normally under different conditions.

- The surrounding environment should be dry and well-ventilated to maintain normal operation.
- Stay away from areas concentrated with toxic and harmful gases to avoid equipment corrosion.
- Keep away from flammable, explosive, and corrosive materials to ensure safe operation.

### 5.2 Space Requirements

Sufficient space around the equipment is required to ensure effective heat dissipation and facilitate maintenance. The following figure shows the minimum clearance requirements (Unit:mm).

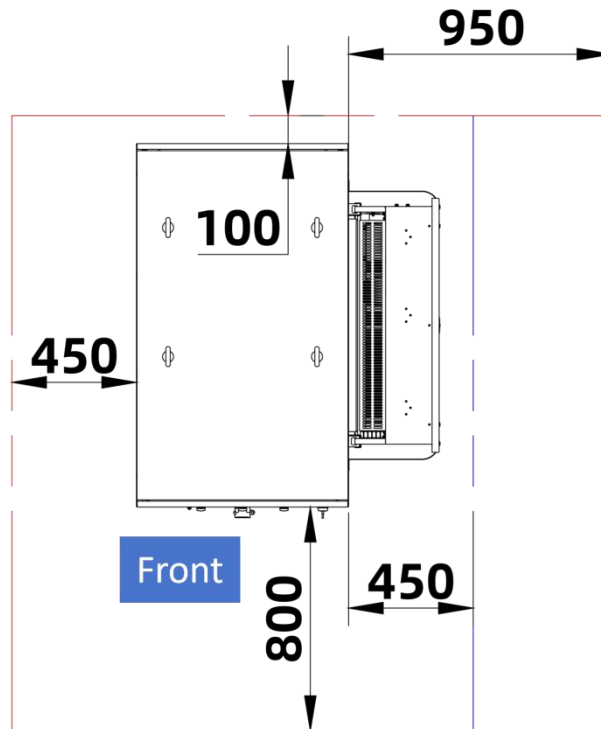

Figure 5-1 Space Requirement

### 5.3 Foundation Requirements

Before starting foundation construction, conduct thorough research on various conditions of the equipment installation site, including geological conditions and environmental climate factors. The rationality of foundation construction determines the stability of the equipment, the smooth opening and closing of doors, and the smooth operation thereafter. To prevent significant issues or troubles during equipment placement and maintenance, design and construct the foundation according to corresponding standards to meet the requirements for equipment support, cable routing, and future maintenance.

The foundation construction should at least meet the following requirements:

- The bottom of the foundation pit must be compacted and leveled.

- The foundation should provide sufficient bearing support to handle the equipment's weight.
- To avoid rainwater erosion of the cabinet base and interior, it is recommended to elevate the cabinet, making the foundation 200mm above the highest historical water level of the installation site's ground.
- Take appropriate drainage measures based on local geological conditions.

## 5.4 Forklift Requirements

During the installation and maintenance of the ESS, if a forklift is needed to move the cabinet or battery pack, follow these guidelines:

### Fork Recommendations:

- The recommended fork size is length 1500mm to 1800mm, width 80mm to 160mm, and thickness 25mm~50mm.

### Cabinet Installation:

- Moving the ESS after installing the battery pack is strictly prohibited to ensure safe operation.
- When using a forklift for cabinet installation, the forklift's load capacity should not be less than 3.5 tons to ensure stability.

### Battery Pack Installation and Maintenance:

- When using a forklift for battery pack installation and maintenance, the forklift's load capacity should not be less than 1 ton to ensure safe operation.
- The required lifting height depends on the foundation height. When the foundation height is  $\leq 0.3\text{m}$ , the lifting height should be  $\geq 2\text{m}$ .

When the foundation height is  $>0.3\text{m}$ , the lifting height should increase accordingly.

### **Moving and Handling:**

If the installation site is flat, use a forklift to move the cabinet.

- When using a forklift to move the cabinet, the forklift's load capacity should be at least 3.5 tons.
- Move and lower the equipment slowly and steadily to ensure safety.
- Ensure the forks are inserted into the designated fork holes at the bottom of the product. Moving through other locations is strictly prohibited.
- It is recommended to use the provided sealing plates to seal the fork holes after on-site installation.

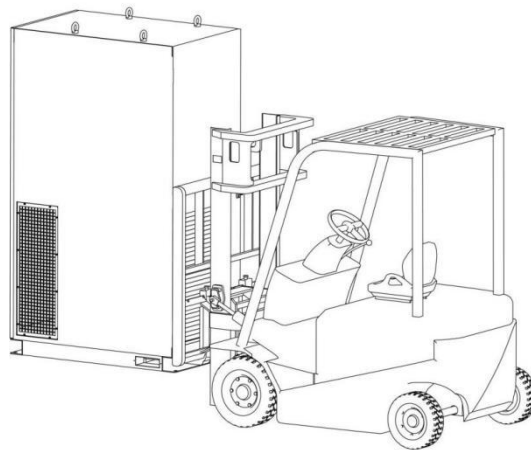

Figure 5-2 Forklift installation

When performing hoisting operations for the cabinet, strictly follow these principles to ensure the safety and effectiveness of the hoisting process:

### **Pre-Hoisting Operation Requirements:**

- The entire hoisting process must be directed by professional personnel to ensure the safety and accuracy of the operation.

- Hoisting operations are strictly prohibited under adverse weather conditions such as heavy rain, fog, and strong winds. Hoisting should be performed in clear, windless weather.
- At the hoisting site, personnel are strictly prohibited from standing within 5m to 10m of the operation area, especially under the hoisting arm and under the lifted or moved equipment, to avoid accidents and injuries.
- Ensure the hoisting ropes are securely connected, and the strength of the hoisting ropes meets the weight requirements of the product.
- Personnel involved in hoisting must undergo relevant training and pass qualification tests before starting work.

#### **Hoisting Process Requirements:**

- The crane's lifting capacity should reach or exceed 5 tons, with a working radius of  $\geq 3\text{m}$ . The crane and cables must meet relevant requirements to ensure smooth hoisting operations.
- Hoisting tools must be fixed to load-bearing fixtures or walls to ensure stability.

#### **Hoisting Operation Principles:**

- Unauthorized personnel are strictly prohibited from entering the hoisting area, especially under the hoisting arm.
- Maintain a suitable crane position to avoid long-distance hoisting, ensuring equipment stability. The diagonal tilt angle of the cabinet should be  $\leq 5^\circ$ .
- Ensure the angle between the two cables is  $\leq 90^\circ$ , lift and lower the equipment gently, and ensure the cabinet descends slowly and steadily to prevent impact on internal equipment.

- When the cabinet contacts the base, wait until the base is evenly stressed before removing the hoisting cables.
- Dragging wire ropes and hoisting tools is prohibited to prevent equipment collisions.
- Securely fix the first hoisted cabinet before hoisting subsequent cabinets.

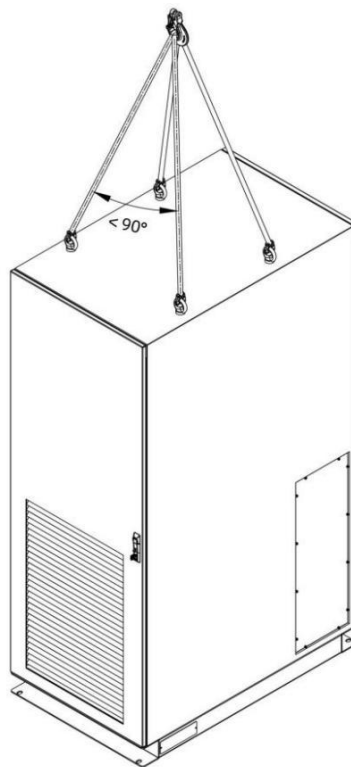

Figure 5-3 Hoisting installation



## 6 Installation





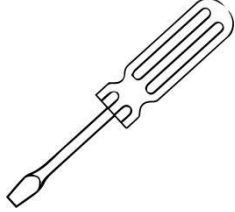
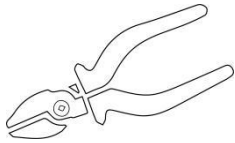

### 6.1 Tools

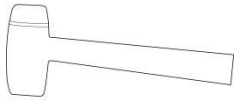
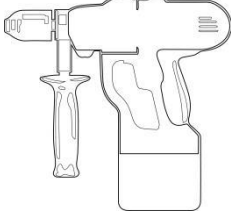
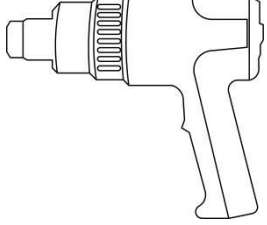
This chapter lists only the essential tools required for system installation.

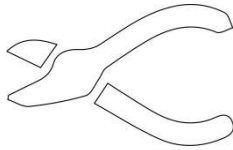
Due to varying site conditions, additional tools may be necessary.

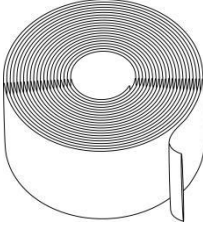
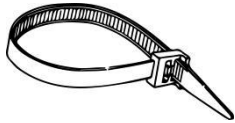
Installers should assess the actual on-site situation and prepare any supplementary tools as needed.

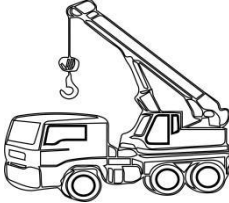
 <p>Insulated Phillips Torque Screwdriver</p>	 <p>Socket Wrench</p>	 <p>Insulated Flathead Torque Screwdriver</p>	 <p>Diagonal Pliers</p>
 <p>Wire Stripper</p>	 <p>RJ45 Crimping Tool</p>	 <p>Marker</p>	 <p>Utility Knife</p>
 <p>Leveling Ruler</p>	 <p>Vacuum Cleaner</p>	 <p>Multimeter</p>	 <p>Tape Measure</p>
 <p>Rubber Mallet</p>	 <p>Impact Drill</p>	 <p>Hydraulic Crimping Tool</p>	 <p>Heat Gun</p>

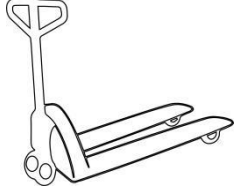
 Wire Cutter	 Impact Drill Bits	 Heat Shrink Tubing	 Cable Ties
 Ladder	 Crane	 Electric Forklift	 Manual Forklift

## 6.2 Pre-Installation Check

- Verify all delivered items against the packing list to ensure completeness
- Confirm that the received cabinet matches the ordered model number and specifications.
- Remove packaging carefully. While removing the bolts from the wooden pallet, ensure the equipment remains stable to prevent tipping or damage.
- If the installation environment is poor, take dustproof and anti-condensation measures after removing the packaging, such as using dust covers, plastic film, or cloth.
- Inspect the cabinet exterior and internal components for any signs of damage
- If a custom steel frame is required on-site, confirm that the steel frame has been installed in place and verify the placement direction of the equipment.

## 6.3 Installing the Battery Cabinet

### Prerequisites

- According to the guidelines in [Location Requirements](#), [Space Requirements](#) and [Foundation Requirements](#), choose the suitable installation location.
- Prepare four M16x50 fasteners.

### Procedure

Step 1: Use a forklift or crane to move the equipment to the chosen installation location, ensuring the base mounting holes align with the drilled holes.

Step 2: Secure the equipment at all four bottom corners with M16 fasteners as shown in Figure 6-1.

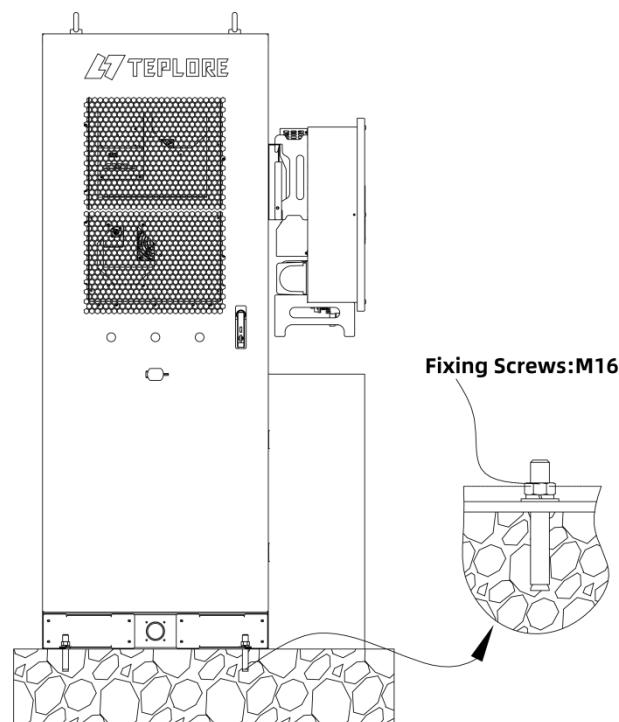

Figure 6-1 Screw the cabinet

## 6.4 Installing the Inverter

The battery cabinet and hybrid inverter arrive unassembled. After installing the cabinet, mount the inverter onto the right side panel of the cabinet.

### Prerequisites

#### [Installing the Battery Cabinet](#)

### Procedure

Four mounting holes for the inverter are provided on the right side panel of the cabinet, as shown in Figure 6-2.

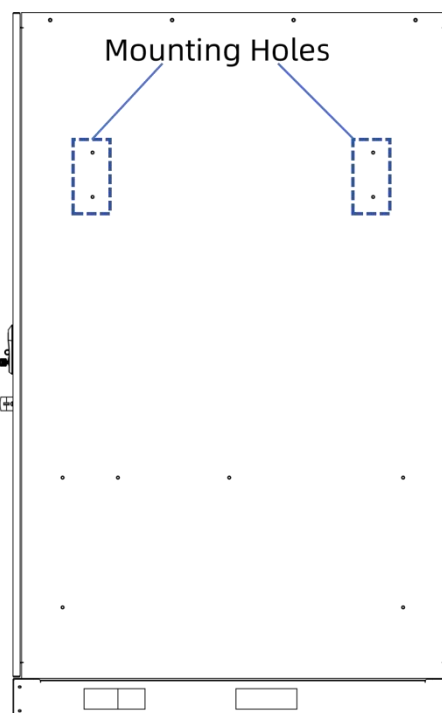

Figure 6-2 Mounting holes of the inverter

Figure 6-3 display the installation sequence of the two components: inverter bracket and inverter.

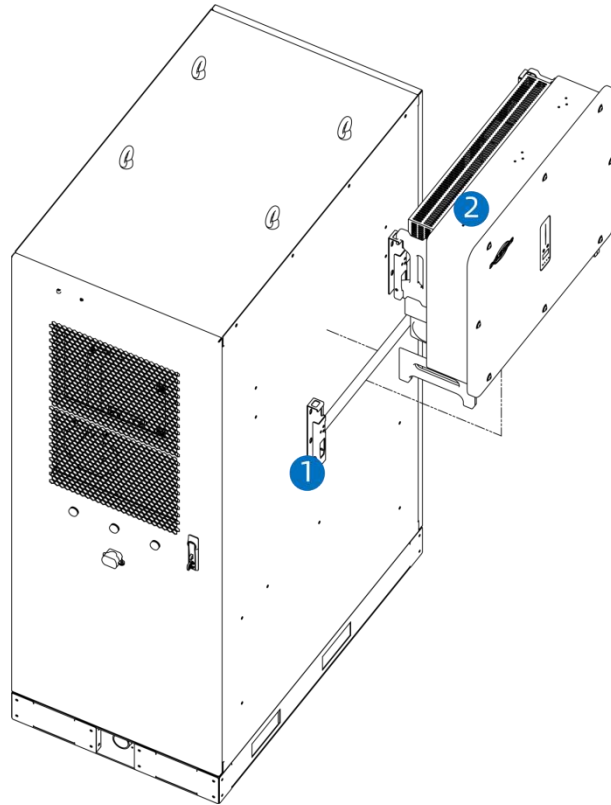

Figure 6-3 Install the inverter

Step 1: Align the inverter bracket with the holes on the cabinet as shown in Figure 6-2 and Secure the inverter bracket to the inverter bracket with M10 bolts.

Step 2: Lift the inverter, and hang the back rail on the fixed bracket carefully.

Step 3: Secure the inverter to the inverter bracket with M6 screws.

#### Note

For details of installing the inverter, refer to the “Mounting the Inverter” section in the user manual of the inverter.

## 6.5 Follow-up Procedure

1. Open the cabinet door and check all internal components for looseness or deformation, and inspect communication cables for secure connections.
2. Refer to the [Electrical Connections](#) chapter for electricity connections.

## 7 Electrical Connections

The electrical connection for the ESS consists of the following parts:

- Grounding of the battery cabinet.
- External connection through the inverter.
- Connection between the battery cabinet and the inverter.

### Note

For details about the electrical connections of the inverter, refer to the inverter user manual.

### 7.1 Grounding the Battery Cabinet

#### Prerequisites

- Recommended cable: cross-sectional area  $\geq 50 \text{ mm}^2$
- M10 fastener and compatible terminal

#### Procedure

Step 1: Ground the enclosure of the cabinet according to on-site installation requirements.

Step 2: Ground the grounding copper bar inside the cabinet.

1. Route the external grounding cable through the bottom entry port of the cabinet.
2. Crimp a terminal to the grounding cable.
3. Connect the grounding terminal to the grounding bar with the M10 fastener as shown in Figure 7-1.

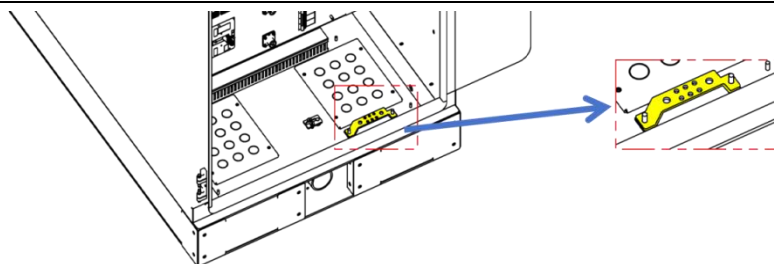

Figure 7-1 Grounding connection

## 7.2 Connecting Externally via the Inverter

Following are the steps for the external wiring of the Tensorpack M ESS through the inverter. For detailed procedures, refer to the corresponding sections (listed under **Reference**) in the inverter user manual.

Step 1: Connecting the inverter to the external power supply.

**Reference:** The instructions of **On-grid AC side** in section “AC Connection”

Step 2: Connecting the inverter to the on-site PV string through terminal PV1~PV4.

**Reference:** Section “PV String Connection”

Step 3: Connecting the inverter to the external meter through the **Meter** port in **COM2**.

**Reference:** Section “Communication Connection” .

## 7.3 Interconnecting the Battery Cabinet and Inverter

### Cable Requirements

All cables are supplied with the product and can be identified by the cable labels at both ends for correct terminal connection.

You must route all interconnecting cables through the cable entry at the cabinet bottom as indicated by the red box in Figure 7-2.

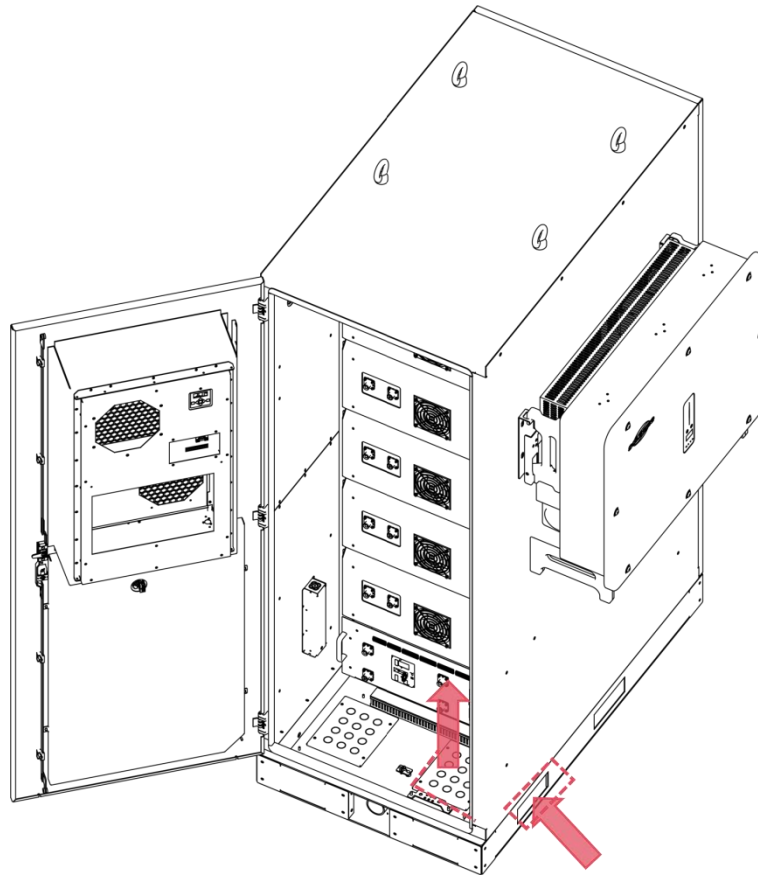

Figure 7-2 Cable routing

## Connection Reference

All connection terminals are located as shown in Figure 7-3.

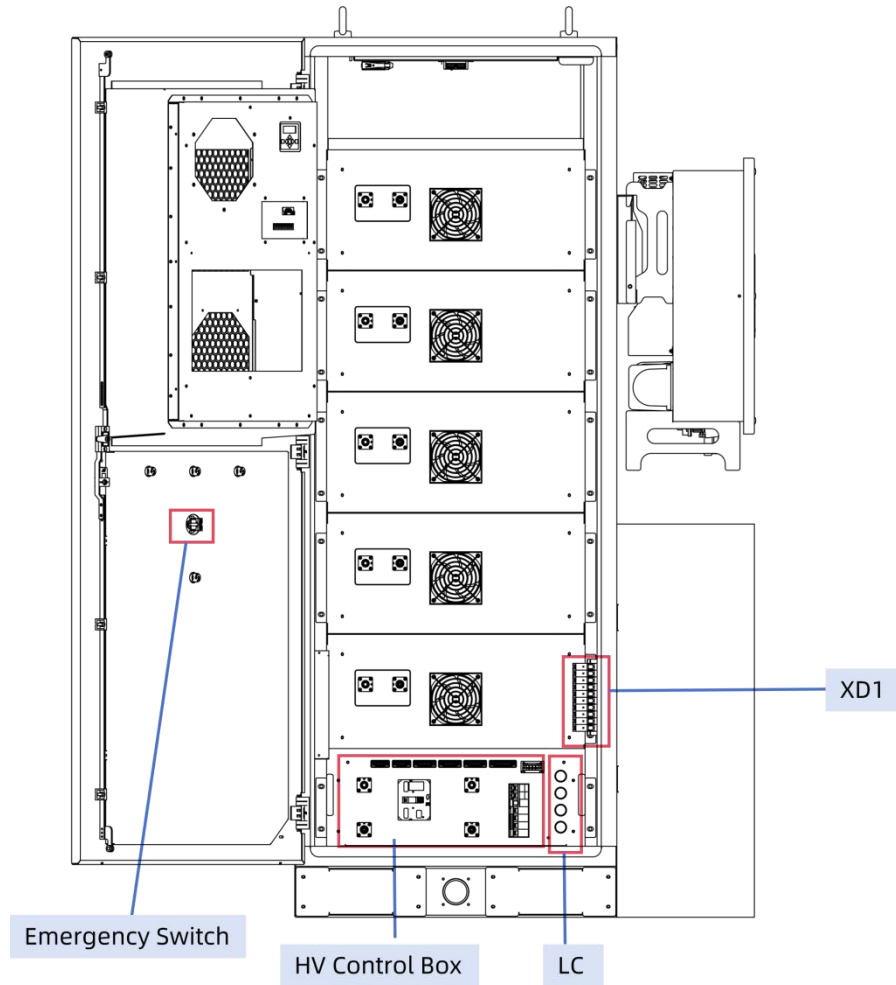

Figure 7-3 Positions of terminals

The interconnection between the battery cabinet and inverter contains the following parts.

- DC circuit connection
- Back-up output connection
- Communication connection
- Grounding connection.

Table 7-1 specifies all cable connections between the battery cabinet and inverter. The table columns are defined as follows:

- **Component:** Specifies the component of the the battery cabinet or inverter where the terminal to be connected is located.

- **Terminal:** Specifies the terminal to be connected. You can locate the specific terminal by label on the corresponding component.
- **Cable Label:** Specifies the identifier on the corresponding end of the cable to be inserted into this terminal.

Battery Cabinet			Inverter		
Component	Terminal	Cable Label	Component	Terminal	Cable Label
<b>DC circuit connection</b>					
HV Control Box	P+	RACK:P+	BAT	BAT+	Battery+
	P-	RACK:P-		BAT-	Battery-
<b>Back-up output connection</b>					
XD1	1	XD1:1	BACK-UP	L1	BACK-UP:L1
	3	XD1:3		L2	BACK-UP:L2
	5	XD1:5		L3	BACK-UP:L3
	7	XD1:7		N	BACK-UP:N
	9	XD1:9		PE	BACK-UP:PE
<b>Communication connection</b>					
Emergency Switch (ES)	1	ES:1	COM2	15	COM2:15
	2	ES:2		16	COM2:16
LC	LAN2	LC:LAN2	R2MD	LAN	R2MD:LAN
<b>Grounding connection</b>					
PE	PE	PE	PE	PE	PE

Table 7-1 Connection between the inverter and battery cabinet

#### Notice

- To ensure the AC auxiliary power of the battery cabinet operates correctly, you must complete the back-up output connection.
- The cables, ES:1 and ES:2, have already be connected to the battery cabinet.

- Before you connect R2MD:LAN and LC:LAN2, you should connect the R2MD communication module to the COM1 port of the inverter(referring to “Communication Module Connection” in the inverter user manual.)
- The grounding connection between the battery cabinet and the inverter shall be made as follows:
  - The battery cabinet grounding terminal is located at the grounding bar inside the cabinet, as shown in Figure 7-1 (referring to [Grounding the Battery Cabinet](#) ).
  - The inverter grounding terminal is located at the lower right side of the inverter, as shown in the following figure (connecting to either grounding terminal).

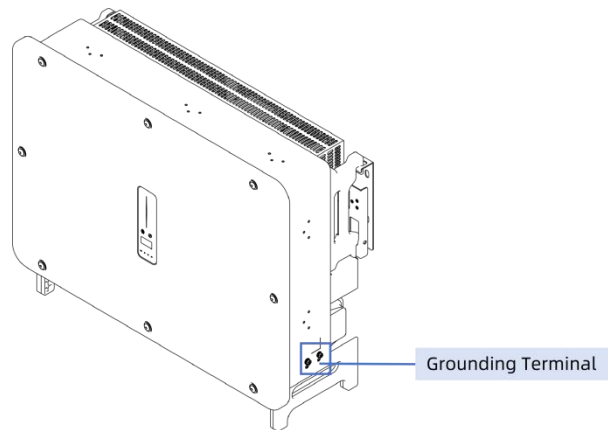

## 7.4 Installing the Cable Protective Cover

After completing electrical connections, install the cable protective cover on the right side panel of the cabinet. Four mounting holes are shown in Figure 7-4.

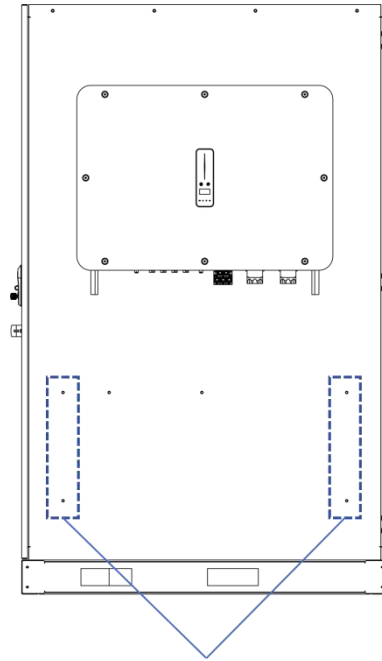

Mounting Holes

Figure 7-4 Mounting holes of the cover

Align the cable protective cover with the holes on the cabinet as shown in Figure 7-4 and secure the cover to the cabinet with M5 screws as shown in Figure 7-5.

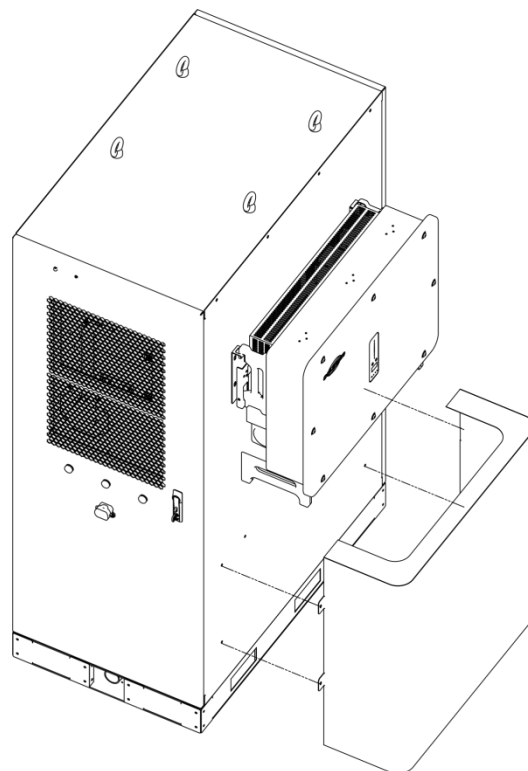

Figure 7-5 Install the cable protective cover

## 8 System Power-On and Power-Off

When you perform the first commissioning, you must:

- Install the Cloud monitoring App (IntegHub) with latest version.



- Contact Teplore to obtain an App account.
- After logging into IntegHub for the first time, change the default password immediately.

### 8.1 Powering On the System

#### Prerequisites

- Complete all checks before power-on.
- Make sure that the external distribution circuit breaker is closed.

#### Procedure

Figure 8-1 displays circuit breakers on the HV control box and indicates the direction to close these circuit breakers.

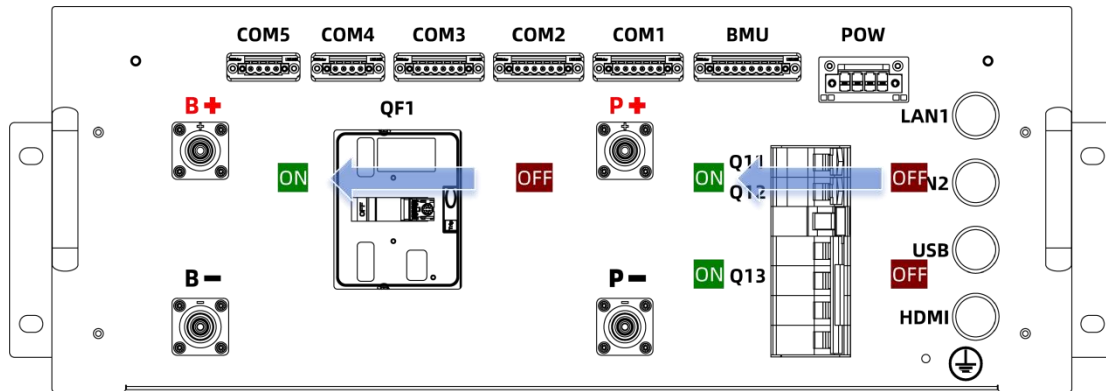

Figure 8-1 Circuit breakers on HV control box

According to the actual requirement, you can choose the on-grid startup or off-grid startup mode.

### On-Grid Startup

Step 1: Open the battery cabinet doors.

Step 2: Close the DC circuit breaker **QF1**.

Step 3: Close the AC auxiliary power circuit breaker **Q11**.

Step 4: Close the air conditioner power circuit breaker **Q12**.

Step 5: Close the battery cabinet doors and rotate the On-Off switch on the cabinet door to the "ON" position.

Step 6: On the inverter, rotate the DC switches to the "ON" position.

### Off-Grid Startup

Step 1: Open the battery cabinet doors.

Step 2: Close the DC circuit breaker **QF1**.

Step 3: Close the DC auxiliary power circuit breaker **Q13**.

Step 4: Rotate the On-Off switch on the cabinet door to the "ON" position.

Step 5: Wait until confirm that the inverter starts successfully and the backup output is normal.

Step 6: Close the AC auxiliary power circuit breaker **Q11**.

Step 7: Close the air conditioner power circuit breaker **Q12**.

Step 8: Turn off the DC auxiliary power circuit breaker **Q13**.

Step 9: Close the battery cabinet doors.

Step 10: On the inverter, rotate the DC switches to the "ON" position.

#### Note

For details about about the back-up loads, refer to the "Back-up/Off-grid Statement" section in the inverter user manual.

## 8.2 Powering Off the System

### Procedure

Figure 8-2 displays circuit breakers on the HV control box and indicates the direction to turn off these circuit breakers.

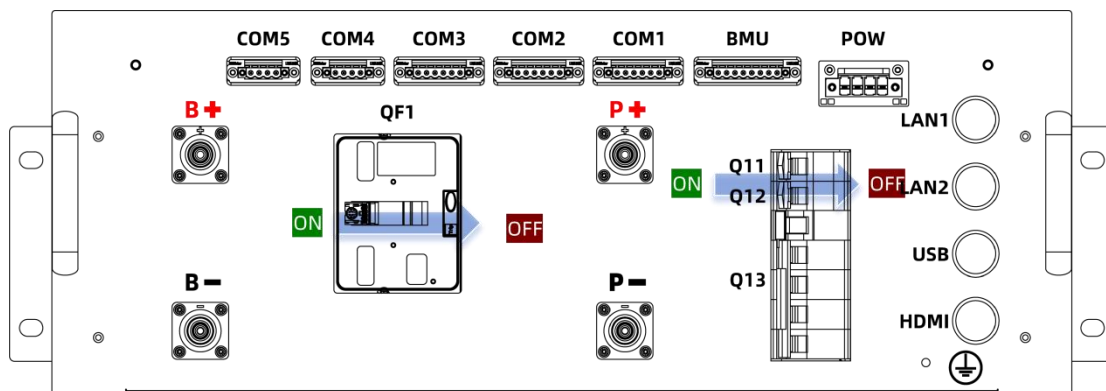

Figure 8-2 Circuit breakers on HV control box

### On-Grid /Off-Grid Shutdown

Step 1: Shut down the inverter through the IntegHub App or the button on the display first.

Step 2: Rotate the On-Off switch on the battery cabinet door to the "OFF" position.

Step 3: Open the battery cabinet doors.

Step 4: Turn off the air conditioner power circuit breaker **Q12**.

Step 5: Turn off the AC auxiliary power circuit breaker **Q11**.

Step 6: Turn off the DC circuit breaker **QF1**.

Step 7: Close the battery cabinet doors.

Step 8: On the inverter , rotate the DC switch to the "OFF" position.

## 9 Contact Information

If you have any questions about this product, please contact us.

**Technical Support Email:** [support@teplore.com](mailto:support@teplore.com)

To enable faster and more efficient service, we kindly request your assistance in providing the following information:

- Project name
- Product model
- Serial number
- Brief description of the issue

## Appendix: Update Record

Revision	Updated Information	Date
R1.0	Initial document for Tensorpack M Hybrid ESS M120-50	2026-03-26