



Tensorpack M

Hybrid Energy Storage System

Maintenance Manual

(M217-50, M241-50)

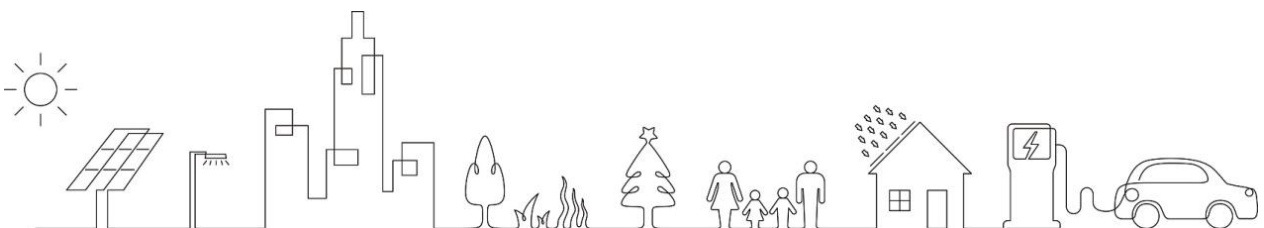

Legal Notice

Copyright © Teplore Co., Ltd. 2026. All rights reserved.

Without the written consent of the company, the content of this document may not be extracted, reproduced or disseminated in any form to entities and individuals, either in part or in full.

As Teplore is dedicated to the continuous iteration and update of its products, this document is subject to change owing to product version upgrade or other reasons. This document is used as a guide only, and all statements, information and recommendations contained herein do not constitute any express or implied warranty. Pictures or interfaces provided in this document are for illustration only and may vary depending on product versions or market areas.

Teplore Co., Ltd.

Headquarters (China):

8th Floor, Building 2, Keya Phase II, 59 Tianyuan West Road, Jiangning District, Nanjing

European Office:

Haraszti út 48, Budapest, 1239 Hungary

Website: www.teplore.com

E-mail: info@teplore.com

Tel.: +86 2552136163

Table of Contents

Abbreviation and Definition	5
1 About This Document	6
1.1 Purpose	6
1.2 Document Conventions	6
2 Safety Precautions	8
2.1 Statement	8
2.2 Label Description	9
2.3 Safety Instructions	10
2.3.1 General Safety	10
2.3.2 Personal Safety	10
2.3.3 Electrical Safety	12
2.3.4 Environmental Requirements	13
2.3.5 Operation and Maintenance Safety	15
3 Routine Maintenance	17
3.1 Precautions Before Maintenance	17
3.2 Daily Maintenance	18
3.3 Quarterly Maintenance	19
3.4 Semi-Annual Maintenance	20
3.5 Annual Maintenance	20
3.6 Enclosure Maintenance	21
3.6.1 Enclosure Surface Cleaning	21
3.6.2 Check Door Locks and Hinges	22
3.6.3 Check Seals	22
3.7 Long-Term Storage	23
4 Component Replacement	24
4.1 Replacing the Battery Pack	24
4.2 Replacing the High-Voltage Control Box	27

4.3 Replacing the Air Conditioner	28
4.4 Replacing the Gas Sensor	29
4.5 Replacing the Battery Pack Fan	30
4.6 Replacing the BMU	31
5 Troubleshooting	33
5.1 Inverter Troubleshooting	33
5.2 Fire Fighting Handling	33
6 Emergency Handling	34
7 FAQ	37
7.1 How to Repaint	37
7.1.1 Pre-Work Preparation	37
7.1.2 Damage Assessment	37
7.1.3 Repairing Minor Damage	38
7.1.4 Repairing Severe Damage	40
7.1.5 Color Code	42
8 Contact Information	43

Abbreviation and Definition

Abbreviation	Definition
BMS	Battery Management System
EMS	Energy Management System
EPO	Emergency Power Off
ESS	Energy Storage System
LC	Local Controller
PCS	Power Conversion System
SPD	Surge Protection Device
UPS	Uninterruptible Power Supply

1 About This Document

1.1 Purpose

This document provides the guidelines for the following **Tensorpack M** Hybrid Energy Storage System (also referred to as ESS) models. The content covers routine maintenance, component replacement and troubleshooting.

- M217-50
- M241-50

1.2 Document Conventions

Statement

In this document, “equipment” refers to the products, software, components, spare parts, or services related to this document; “the company” refers to the manufacturer (producer), seller, or service provider of the equipment; “customer” refers to the entity that transports, stores, installs, operates, or maintains the equipment.

Symbol Conventions

To alert readers or users about the precautions that should be observed during installation, operation, and maintenance to ensure personal and equipment safety, this document uses the following safety symbols:

 **DANGER**

Indicates a high potential hazard that, if not avoided, will result in death or serious injury.

 **WARNING**

Indicates a moderate potential hazard that, if not avoided, may result in death or serious injury.

 **CAUTION**

Indicates a low potential hazard that, if not avoided, may result in minor or moderate injury.

NOTICE

Indicates a potential hazard that, if not avoided, may result in equipment malfunction or property damage.

NOTE

Provides supplementary explanation or key details in the main text. It is not a safety alert and does not contain information related to personal injury, equipment damage, or environmental hazards.

2 Safety Precautions

2.1 Statement

Before installing or operating the equipment, please read all safety instructions carefully. It is mandatory to strictly adhere to all safety precautions, safety markings on the equipment, applicable laws, regulations, standards, and norms.

In this manual, the terms “danger” , “warning” , “caution” and “note” are not limited to all safety matters that should be followed. Customers must also comply with relevant international, national, or regional standards and industry practices. The equipment should be used in an environment that meets the requirements. Incorrect operation can lead to product damage and property loss, and even cause personal injury, for which the company is not liable.

The company is not responsible for any of the following situations or their consequences:

- Equipment damage caused by force majeure such as floods, flash floods, typhoons, earthquakes, tsunamis, lightning, volcanic eruptions, war conflicts, government bans, strikes, etc.;
- Damage caused by transportation by the customer or a third party authorized by the customer;
- Damage caused by failure to comply with the requirements of this manual;
- Installation and operation that do not comply with relevant international, national, or regional standards;
- Failure to observe the safety precautions and operating instructions specified in this manual;
- Failure to follow the safety markings indicated on the equipment;
- Installation and use of the equipment by unqualified personnel;
- Customer-provided non-standard tools that do not meet relevant standards;
- Damage caused by the customer’s intentional acts, gross negligence, operational violations, or reasons not attributable to the company.

2.2 Label Description

Labels on the equipment includes essential information for safely operating the product. It is strictly forbidden to intentionally damage or remove these labels. If the labels become blurred, damaged, or lost, they must be replaced immediately. The machine identification includes:





Label	Description
	Indicates high voltage danger; touching may result in an electric shock hazard.
	Advises caution for safety; avoid unnecessary contact to prevent personal injury.
	Indicates that this is a protective ground (PE) and must be securely grounded to ensure personal safety.
	Indicates the presence of lethal high voltage. After disconnecting the equipment from the external power source, wait 5 minutes before touching any internal conductive components.
	Indicates that the manual should be read before performing any operations on the product.

Table 2-1: Label description

2.3 Safety Instructions

2.3.1 General Safety

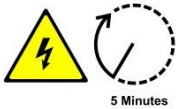
DANGER

- Touching the power grid or terminals and contacts connected to the ESS may cause fatal electric shocks.
- There is lethal high voltage inside the product; heed and follow the warning signs on the product.
- Damaged equipment or product malfunctions may cause electric shocks or fires.

2.3.2 Personal Safety

DANGER

- During equipment operation, unauthorized or incorrect operations can cause fires, electric shocks, or explosions, leading to product damage, property loss, and even personal injuries.
- During work, it is strictly forbidden to wear various conductive objects such as watches and necklaces to avoid electric shock injuries.
- During work, it is mandatory to use regulatory standard specialized insulated tools to avoid electric shock injuries or short circuits.

General Requirements

- If faults that may cause personal injury or equipment damage are discovered during work, stop the operation immediately and, after confirmation by a responsible person, take effective protective measures.
- Before powering on the equipment, ensure it is fully installed and checked by professionals.

-
- It is forbidden to touch or indirectly contact powered equipment; voltage at the contact points should be measured before touch to ensure there is no risk of electric shock.
 - Do not touch operational fans with fingers or tools to prevent personal injury or equipment damage.
 - In case of a fire, immediately evacuate the building or equipment area and press the fire alarm or call the fire department.

Personnel Requirements

- Personnel performing electrical operations on this product must have professional training and relevant operation certificates.
- Operators should have a certain level of electronic, electrical wiring, and mechanical expertise, and be fully familiar with the internal electrical principles of the product.
- Operators should be familiar with various safety precautions and relevant standards of their country/region.
- Only qualified professionals or trained personnel are allowed to install, operate, and maintain the equipment.
- Only qualified professionals are allowed to remove safety facilities and service equipment.
- Installation or operation personnel should have the ability to respond to emergencies or unexpected situations that may arise during installation or trial operation.
- Personnel involved in special scenarios such as electrical operations, working at heights, or operating special equipment must have the special operation qualifications required by their local country/region.
- Except for personnel operating the equipment, other individuals should not approach the equipment.

2.3.3 Electrical Safety

DANGER

- Before making electrical connections, ensure the equipment is undamaged, as damage may cause electric shocks or fires.
- Both the battery side and grid side may produce voltage; always use a standard voltmeter to ensure no voltage before touching.
- Disconnect the power source of the ESS; the battery will not immediately lose power, wait 10 minutes to ensure the equipment is completely de-energized before operating.
- Prevent foreign objects from entering the equipment during work as they may cause short circuits, damage, power supply derating, or personal injuries.

WARNING

- Ensure the system is reliably grounded before performing electrical installations or connections; otherwise, there may be a risk of electric shock when touching the product.
- Do not damage the grounding conductor.

General Requirements

- Installation, operation, and maintenance must be performed according to the manual's sequence; do not arbitrarily change the installation order, modify or alter the equipment.
- Permission from local electrical authorities is required for grid-connected operation.
- Erect warning signs or set up safety barriers near the equipment, and strictly prohibit non-working personnel from entering.
- Disconnect the equipment itself and the upstream and downstream switches before installing or removing power cables.

- If liquid enters the equipment, immediately turn off the power and do not continue using it.
- Before operating the equipment, carefully check that the tools used meet the requirements and are registered; after the operation, collect them back to prevent them from being left inside the equipment.

Cable Requirements

- Before installing power cables, ensure the cable labels are correct and the cable terminals have been insulated.
- The selection, installation, and routing of cables must comply with local laws, regulations, and standards.
- During the laying of power cables, avoid looping or twisting. If the power cable is found to be too short, replace it; do not make joints or soldering points in the power cable.
- All cables must be securely connected, well-insulated, and of appropriate specifications.

Grounding Requirements

- The equipment grounding impedance should meet local electrical standards.
- The equipment should be permanently connected to protective ground. Before operating the equipment, check the electrical connections to ensure the equipment is reliably grounded.
- Do not operate the equipment without installing a grounding conductor.

2.3.4 Environmental Requirements

DANGER

It is strictly forbidden to pile flammable and explosive materials around the installation site.

WARNING

- Install the equipment away from liquids, and strictly prohibit installation under locations such as water pipes and air vents where condensation can occur.
- Do not install under air conditioning vents, ventilation ducts, or windows where leakage is possible to prevent liquids from entering the equipment and causing faults or short circuits.
- The equipment should be installed in a clean, neat, and well-ventilated area; do not pile miscellaneous items within a 2-meter radius.
- Do not install the equipment in environments with radioactive radiation, high salinity, strong vibration or magnetic fields, or where fungi can easily grow.

NOTICE

Avoid opening the maintenance door of the ESS for maintenance and inspection under adverse conditions with air humidity >95% or during rainy and humid weather.

- Moisture intrusion can damage the product. To ensure the normal and safe operation of the system, pay attention to environmental humidity during routine maintenance and inspection.
- The installation site should meet the requirements for equipment ventilation and personnel evacuation.
- Before installing the equipment, ensure the installation surface is solid, free of adverse geological conditions, and meets the load-bearing requirements of the equipment.
- Before maintenance, clean the accumulated water, ice, snow, or other debris on top.
- After installing the equipment, clear empty packaging materials from the area.

2.3.5 Operation and Maintenance Safety

WARNING

- During routine operation, ensure the equipment cabinet doors are closed and locked, and the keys are removed and kept by a designated person to prevent unauthorized access and accidents.
- Except for necessary checks and maintenance, do not open the cabinet doors to prevent moisture from entering the equipment and causing short circuits and damage.
- Except for personnel operating the equipment, other individuals should not approach the equipment.
- When performing maintenance and repairs, personal protective equipment must be equipped.

NOTICE

- Do not spray any devices inside or outside the equipment.
- Do not clean the equipment with cleaning agents or expose it to corrosive chemicals.

General Requirements

- Personnel operating the equipment must be professionals and trained personnel.
- Ensure that the internal devices and systems of the battery system are completely de-energized.
- Erect clear warning signs at the disconnection points to prevent dangerous accidents caused by misoperation.
- Set up warning signs or safety barriers in the operation area.
- During checks or maintenance, ensure at least two personnel are present.

- Wear protective equipment, including safety goggles, insulated gloves, insulated shoes, and safety helmets, as necessary to ensure the safety of personnel and equipment.
- After operations, lock the maintenance door of the ESS and securely store the keys.

3 Routine Maintenance

NOTE

For details about how to power off the ESS, refer to the instructions in “Tensorpack M Hybrid Energy Storage System User Manual (M217-50, M241-50)” .

3.1 Precautions Before Maintenance

Before performing any maintenance, carefully read and comply with the following safety requirements. Maintenance must be carried out only by qualified and trained personnel. Unauthorized operations may result in equipment damage, personal injury, or fire hazard.

WARNING

- Do not open the cabinet door for maintenance during rain, snow, hail, or level 6 or stronger wind.
- Avoid opening the cabinet door during precipitation, fog, or high-humidity conditions (relative humidity >80%). After closing the door, ensure the sealing gasket is flat and properly seated to maintain an effective environmental seal.
- To reduce the risk of electric shock, do not perform any maintenance or repair procedures not explicitly described in this manual. For additional service, contact Teplore to obtain authorized support.

NOTICE

- During clear weather and moderate temperatures, it is recommended to open the cabinet door periodically for ventilation and dehumidification to maintain optimal equipment condition.
- If the system is installed in any of the following non-ideal environments, increase inspection frequency:
 - Temperature $\geq 35^{\circ}\text{C}$ or $\leq 0^{\circ}\text{C}$
 - High-dust, saline, or industrial pollution areas
 - Regions with frequent rainfall or sustained high humidity

Safety Requirements in Maintenance and Repair

- Before connecting or disconnecting any cables, turn off the protection switch of the corresponding circuit.
- Place a warning tag on the disconnected switch to prevent it from being turned on.
- Use a voltage detector rated for the system voltage to verify the absence of electrical potential and confirm the equipment is fully de-energized.
- If live parts are present nearby, cover or wrap them with insulating barriers or electrical tape.
- Prior to beginning repairs, securely connect the circuit under service to the main grounding system using an approved grounding wire.
- After completing the repair, remove the grounding wire from the circuit.

3.2 Daily Maintenance

Log in to Cortex Ecosystem or management software to check alarm list. Verify that no major or minor alarms are active.

For detailed operating instructions, refer to the EMS platform user manual.

3.3 Quarterly Maintenance

Quarterly maintenance can be performed while the system is running without requiring a shutdown.

All inspections of the quarterly maintenance are listed as follows.

Item	Procedure	Requirement
Visual appearance inspection	Visually inspect the overall external condition of the equipment.	No visible coating peeling, scratches, paint loss, or corrosion.
Cabinet surrounding area check	Inspect the area around the cabinet for any foreign objects that may obstruct ventilation or access.	No obstructions present; surrounding area is clean and unobstructed.
Equipment label integrity check	Inspect warning labels, safety signs, and other identification plates on the equipment for clarity and condition.	All labels are securely attached, legible, and undamaged; blurred or damaged labels shall be replaced immediately.
Cabinet side ventilation panel cleaning	Clean dust from the cabinet side ventilation panel using a handheld vacuum.	The Panel is clean and free of dust accumulation or blockage.
Air filter inspection*	Inspect the air filter for dust clogging. Replace if heavily soiled or at the end of its service life.	Filter is clean and unobstructed.
Equipment mounting security check	Carefully inspect the mechanical connection between the equipment and its mounting base to ensure structural stability.	All fasteners are properly tightened with no signs of looseness or damage.

Table 3-1: Quarterly maintenance

NOTE

*Filter inspection intervals may be shortened depending on local environmental conditions. Extension of these intervals is not recommended.

3.4 Semi-Annual Maintenance

NOTE

You must power off the ESS before performing the semi-annual maintenance.

The semi-annual maintenance includes all tasks from quarterly and daily maintenance, in addition to the following inspection activities:

Item	Procedure	Requirement
Door lock and cabinet door check	Inspect the door lock for damage and manually open and close the cabinet doors to verify smooth operation.	Door lock is intact; cabinet doors operate smoothly without jamming or excessive resistance.
Cabinet sealing integrity check	Inspect the control cabinet for overall sealing condition and signs of water ingress.	Sealing is intact; no water leakage observed.
Internal odor inspection	Open the cabinet doors and carefully check for any pungent or abnormal odors, with particular attention to electrical connection points for burnt smells.	No pungent, burnt, or abnormal odors detected.
Terminal visual inspection	Remove all protective panels and visually inspect all terminals and busbar connections for discoloration, carbonization, or surface arcing marks.	Terminals show no signs of overheating, burning, or insulation degradation.
Cable connection check	Inspect the tightness of all cable terminations.	All fasteners are properly secured with no visible looseness.

Table 3-2: Semi-Annual maintenance

3.5 Annual Maintenance

The annual maintenance includes all tasks from semi-annual, quarterly, and daily maintenance, in addition to the following inspection activities:

NOTE

Before performing all inspections except **live connection infrared thermography**, you must power off the ESS.

Item	Procedure	Requirement
Live connection infrared thermography	With the equipment energized, use an infrared thermometer to measure the temperature of all terminals and cables.	Temperatures are normal with no signs of overheating or insulation aging.
Internal cabinet cleaning	Clean the interior of the cabinet using a handheld vacuum cleaner.	No dust, metal debris, or foreign objects inside; airflow paths and component surfaces are clean.
Circuit breaker operation test	Manually operate molded-case circuit breakers (MCCBs) and miniature circuit breakers (MCBs) to verify smooth opening and closing action.	Breakers operate smoothly with no jamming, abnormal noise, or mechanical failure.
Internal cable and fastener inspection	Inspect cables, harnesses, and fasteners inside the cabinet for looseness.	All connections are secure with no looseness or physical damage.
Battery pack fan Inspection	Visually and audibly inspect all battery pack fans	Fans must rotate freely without obstruction, abnormal noise, or significant dust accumulation.
Air conditioner outdoor unit cleaning	Use a high-pressure water gun to wash from the outside air inlet and outlet towards the inside.	The unit must be clean and free of blockages.

Table 3-3: Annual maintenance

3.6 Enclosure Maintenance

3.6.1 Enclosure Surface Cleaning

- **Situation 1:** The surface of the enclosure is only contaminated with mud, dust, etc.

Solution: Wash the enclosure directly with water. Start cleaning from the top and then proceed to the sides and bottom.

NOTE

Avoid directly spraying the front door louvers and side ventilation holes.

- **Situation 2:** The surface is dirty and the topcoat is peeling or damaged.

Solution:

1. Clean the surface with water to remove all dirt.
2. Dry the damaged paint areas with a cloth.
3. Once dry, proceed with repainting as described in [How to Repaint](#).

- **Situation 3:** The primer is damaged and the substrate is exposed.

Solution:

1. Use fine sandpaper to remove rust from the substrate.
2. Proceed with repainting as described in [How to Repaint](#).

3.6.2 Check Door Locks and Hinges

After completing the cleaning process, inspect the locks and hinges of the cabinet to ensure they function properly.

- Verify that the lock linkage slides smoothly.
- Check that the door handle rotates without obstruction.
- If necessary, apply an appropriate lubricant to the lock keyholes and hinges.

3.6.3 Check Seals

Check if the seals are damaged or detached from the cabinet frame.

- Replace any damaged seal immediately.
- If a seal has become detached, press it firmly back into place within the frame channel.

3.7 Long-Term Storage

If the battery energy storage system remains unused for an extended period, perform a charge/discharge cycle every six months. Maintain the state of charge (SOC) between 30% and 40% during this process. Before returning the system to service, ensure all battery units have consistent SOC values.

Before first use after long-term storage, perform at least one full charge cycle to restore the battery to peak performance and ensure stable, reliable energy output.

4 Component Replacement

DANGER

You must power off the ESS before replacing any component.

NOTE

This chapter uses M217-50 as examples for guidance. Procedures for M241-50 are the same.

4.1 Replacing the Battery Pack

Prerequisites

- Power off the ESS.
- Tools required: One Phillips screwdriver (or an equivalent electric screwdriver) .

Procedure

1. Disconnect all cables from the faulty battery pack.
2. Remove the screws securing the decorative panel of the battery pack to remove the panel.

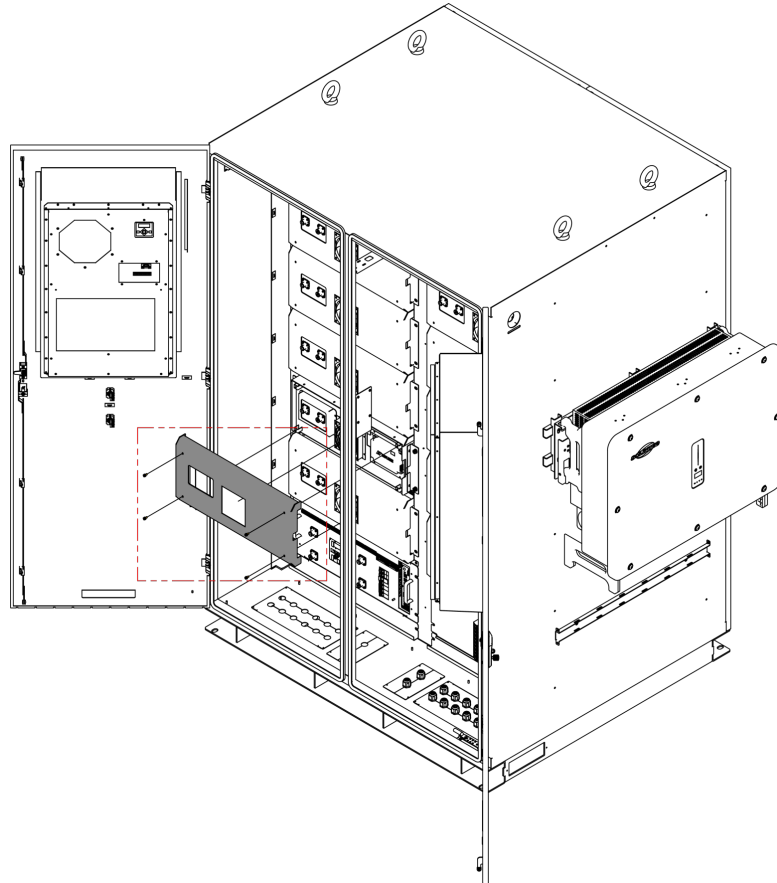

Figure 4-1: Remove the decorative panel

3. Remove the faulty battery pack.
 - a. Remove the screws securing the battery pack mounting lugs to the cabinet frame.
 - b. Extract the pack using a forklift.
 - i. Raise the forklift tines to the height of the pack base.
 - ii. Hold the handles on both sides of the battery pack, and pull the pack to the forklift .

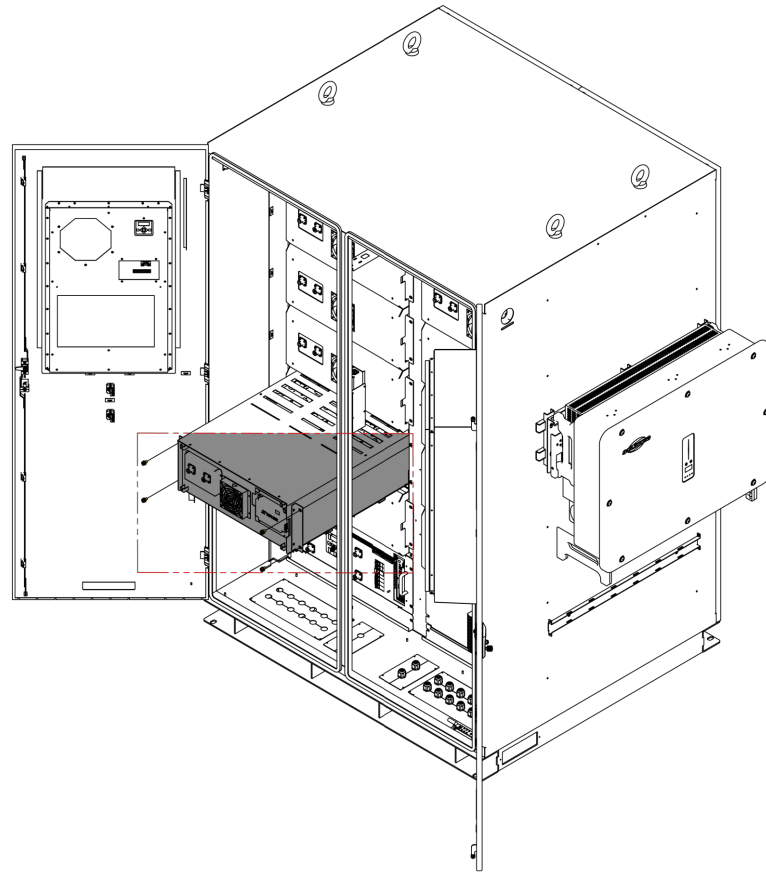

Figure 4-2: Remove the battery pack

4. Install the new battery pack.
 - a. Unpack the new battery pack and remove all packaging materials.
 - b. Have maintenance personnel carefully lift the battery pack and position it securely on the forklift.
 - c. Raise the forklift tines to align with the installation height in the cabinet.
 - d. Slowly push the pack into the cabinet. Ensure the mounting lugs align with the cabinet holes and that the pack engages properly with the guide pin(s) on the fixed beam.
 - e. Install the screws on both sides to secure the battery pack.
5. Secure the decorative panel back onto the battery pack.
6. Reconnect all cables of the battery pack.

Follow-up Procedure

Power on and commission the ESS to confirm that the replaced battery pack is operating normally and stably.

4.2 Replacing the High-Voltage Control Box

Prerequisites

- Power off the ESS.
- Tools required: One Phillips screwdriver (or an equivalent electric screwdriver)

Procedure

1. Disconnect all cables from the faulty HV control box.
2. Remove the faulty High-Voltage (HV) control box from the cabinet.
 - a. Remove the fasteners securing the HV control box to the cabinet frame.
 - b. Carefully slide or pull the HV control box straight out from its mounting base.

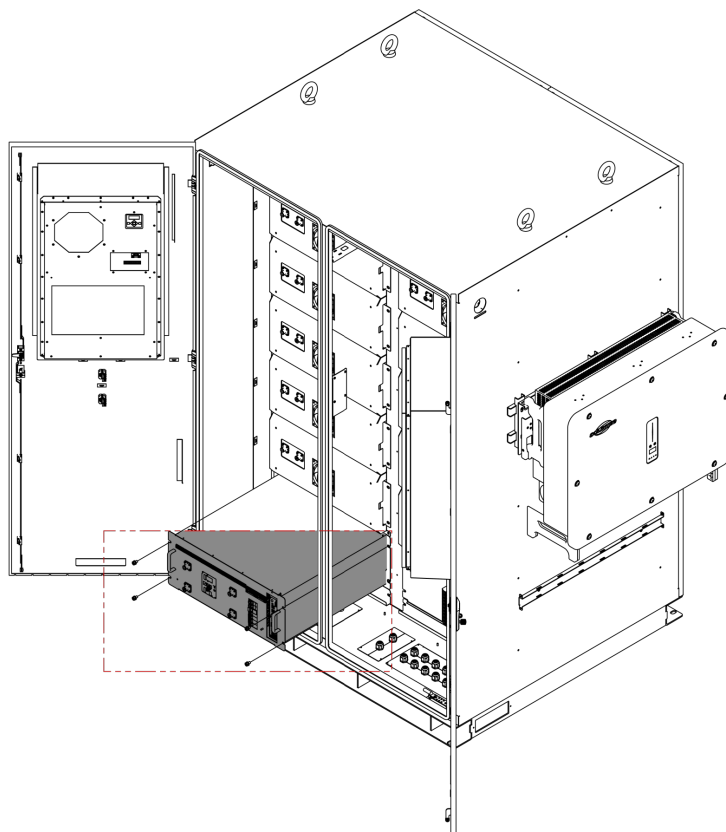

Figure 4-3: Replace HV control box

3. Install the new HV control box.
 - a. Carefully slide the new HV control box fully onto the mounting base until it is properly seated.

- b. Reinstall the fasteners to secure the HV control box to the cabinet frame.
4. Reconnect all cables of the HV control box.

Follow-up Procedure

Power on and commission the ESS to confirm that the replaced HV control box is operating normally and stably.

4.3 Replacing the Air Conditioner

Prerequisites

- Power off the ESS.
- Tools required: One Phillips screwdriver (or an equivalent electric screwdriver)

Procedure

1. Disconnect all cables from the faulty AC unit.
2. Remove the faulty AC unit.
 - a. Remove the fasteners securing the AC unit to the cabinet door.
 - b. Pull out the AC unit and place it on the transport tool.

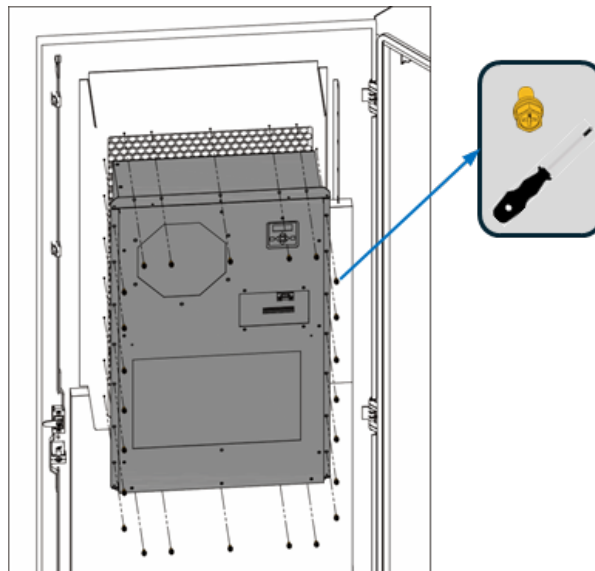

Figure 4-4: Replace Air Conditioner

3. Install the new AC unit.
 - a. Align the new AC unit with the mounting location and carefully slide it into place.
 - b. Secure the AC unit to the cabinet door.
4. Reconnect all cables of the AC unit.

Follow-up Procedure

Power on and commission the ESS to confirm that the replaced AC unit is operating normally and stably.

4.4 Replacing the Gas Sensor

Prerequisites

- Power off the ESS.
- Tools required: One Phillips screwdriver (or an equivalent electric screwdriver)

Procedure

1. Disconnect the communication cables from the faulty gas sensor.
2. Unscrew the corresponding fasteners to remove the gas sensor.
3. Secure the new gas sensor, ensuring the installation direction is the same as before.
4. Reconnect the communication cables.

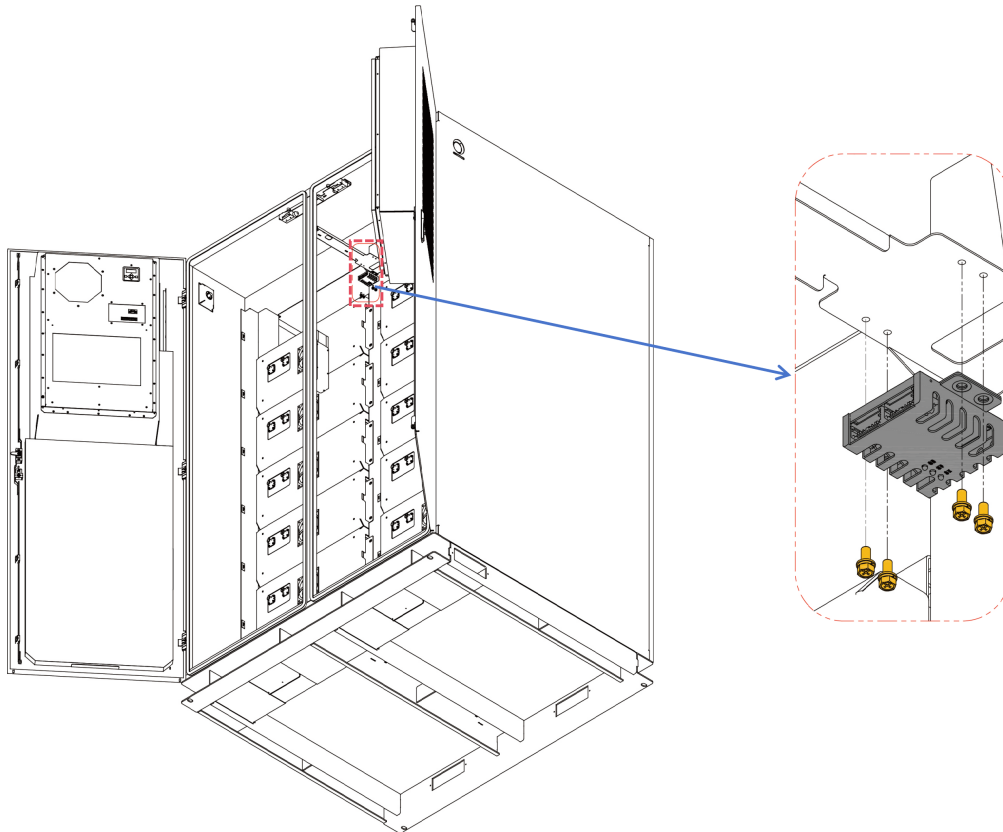

Figure 4-5: Replace gas sensor

4.5 Replacing the Battery Pack Fan

Prerequisites

- Power off the ESS.
- Tools required: One Phillips screwdriver (or an equivalent electric screwdriver)

Procedure

1. Remove the decorative panel of the corresponding battery pack.
2. Unplug the fan harness from the Battery Management Unit (BMU).
3. Remove the fan unit.
 - a. Unscrew the fasteners securing the fan to the battery pack.
 - b. Carefully remove the fan and fan cover—do not pull on the wires.
4. Install the new fan.
 - a. Position the fan with the airflow side facing outward.
 - b. Connect the fan harness to the BMU.

5. Insert the fasteners through the fan cover and fan, then tighten them into the battery pack mounting holes.
6. Reinstall the decorative panel of battery pack.

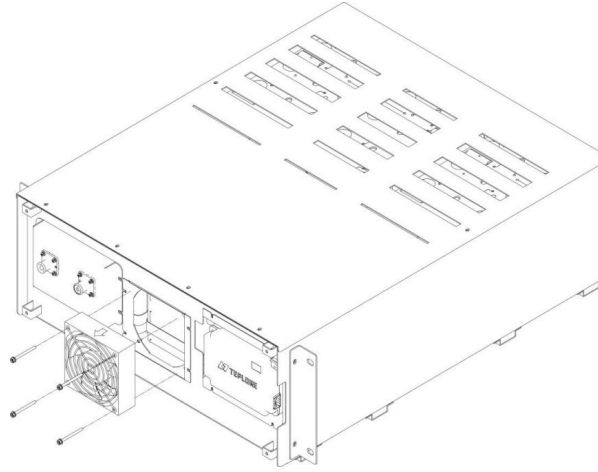

Figure 4-6: Replace Battery Pack Fan

4.6 Replacing the BMU

Prerequisites

- Power off the ESS.
- Tools required: One Phillips screwdriver (or an equivalent electric screwdriver)

Procedure

1. Remove the decorative panel of the corresponding battery pack.
2. Unplug the fan harness and the connection harness between the BMU and other components.
3. Remove the faulty BMU.
 - a. Unscrew the fasteners securing the BMU to the battery pack.
 - b. Slightly lift the BMU to unplug the harness between the battery pack and the BMU.
4. Install the new BMU.
 - a. Connect the new BMU harness to the battery pack.
 - b. Secure the new BMU in the corresponding position on the battery pack, tightening to the specified torque.

5. Reconnect the fan harness and the BMU connection harness.
6. Reinstall the battery pack decorative panel.

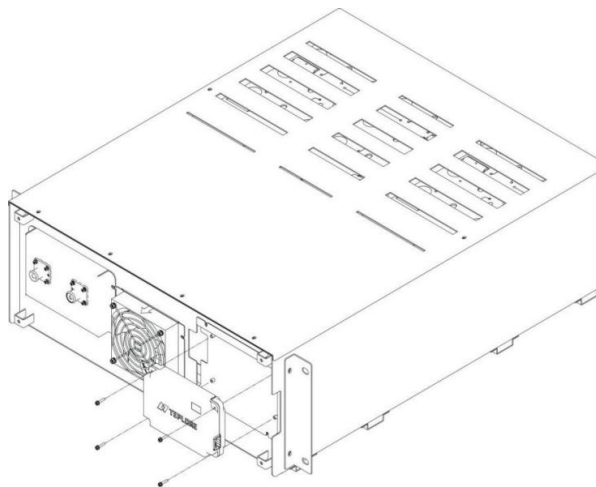

Figure 4-7: Replace the BMU

5 Troubleshooting

5.1 Inverter Troubleshooting

Refer to the “Troubleshooting” chapter in the inverter user manual.

5.2 Fire Fighting Handling

Fire Protection System

The system is equipped with an integrated fire protection system, which includes detection and suppression components to mitigate fire risks.

The fire detector of the system continuously monitors for signs of thermal runaway. Upon confirmation of a fire, the system automatically activates the aerosol suppression unit. The aerosol agent rapidly decomposes the chemical coolant layer, and together they provide total-flooding fire suppression inside the cabinet, extinguishing the fire without manual intervention.

Personnel Response

In the event of a fire, personnel must evacuate immediately and notify the fire department without delay. If necessary, call the local emergency fire alarm number directly.

6 Emergency Handling

In the event of any on-site emergency (including, but not limited to, the following), prioritize personnel safety above all else. Evacuate all individuals at risk and do not proceed with operations if conditions are unsafe.

Battery Falling or Strong Impact

- If the battery has clearly fallen or been impacted, immediately evacuate personnel and notify professionals.
- If there is no visible deformation or damage, no unusual smell, no smoke, and no fire:
 - Warehouse: Evacuate personnel, and professionals use mechanical tools to transfer the battery to a safe location. Allow it to stand for 1 hour while monitoring the temperature to ensure safety before further handling.
 - Project site: Evacuate personnel, close the battery system cabinet door, and professionals use mechanical tools to transfer the battery to a safe location. Allow it to stand for 1 hour, followed by subsequent handling.

Natural Disasters

- Typhoon, flood, heavy rain, severe convective storm
 - Pre-Event: Inspect equipment seals, reinforce or shield equipment as needed, and clear drainage.
 - During Event: If water leakage or flooding occurs, immediately seal leaks and activate drainage pumps.
- Heavy snow, cold wave, extreme freezing conditions
Continuously monitor equipment for ice accumulation and operational status. Promptly perform deicing operations.
- Earthquake
 - Pre-Event: Implement necessary reinforcement measures based on site conditions.

- Post-Event: Do not enter the site until safety is confirmed by qualified personnel after a damage assessment.

Electric Shock

- Immediately disconnect the power supply. Or use insulated tools to separate the victim from the energy source.
- After securing the scene, administer necessary on-site first aid to the victim and call for emergency medical services immediately or transport the victim to the nearest hospital.

Fire

 **DANGER**

- Use carbon dioxide, FM-200, or ABC dry powder fire extinguishers to extinguish the fire.
- Ask firefighters to avoid contact with high-voltage components to prevent the risk of electric shock.
- Elevated temperature may cause battery deformation, damage, and electrolyte leakage. If occurs, use appropriate respiratory protective equipment and maintain a safe distance from potentially toxic gases.
- Immediately evacuate all non-essential personnel. Concurrently:
 - Notify relevant departments.
 - Alert the local fire department based on fire severity.
 - Call for medical services if casualties are present.
- Verify that the ESS external power is disconnected. If not, perform a manual disconnect ensuring personal safety.
- During firefighting:
 - Continuously monitor flammable gas concentration in the fire area.
 - Do not enter the area if an explosion risk is identified.
- Post-Fire:
 - Manage firefighting wastewater according to environmental regulations.

-
- Ensure adequate ventilation and confirm no re-ignition or explosion risk before re-entering the site.

7 FAQ

7.1 How to Repaint

To maintain the equipment’s appearance and prevent corrosion, repaint any area where the paint is peeling or damaged immediately. Please follow the procedures below strictly.

7.1.1 Pre-Work Preparation

- Environmental conditions: Do not perform outdoor repainting in adverse weather conditions such as rain, snow, strong winds, or sandstorms.
- Paint matching: Contact Teplore to obtain the official color sample and prepare paint that meets the specifications. Refer to [Color Code](#) for more information.

7.1.2 Damage Assessment

Identify the type of damage from the table below and follow the corresponding complete repair procedure.

Damage Type	Identification Criteria	Repair Procedure
Minor Damage	<ul style="list-style-type: none"> - Light scratches (not exposing the steel substrate) - Stubborn stains or light surface rust (cannot be wiped off, but without deep corrosion) 	See Repairing Minor Damage .
Severe Damage	Deep scratches (primer is damaged, clearly exposing the steel substrate)	See Repairing Severe Damage .
		Provide the logo or pattern dimensions and color code to a

Damage Type	Identification Criteria	Repair Procedure
Logo or Pattern Damage	Company logo or special patterns are damaged.	professional signage supplier for a custom repair plan.
Impact Dents	Surface dents caused by impact.	<ul style="list-style-type: none"> - Small dent (area $\leq 100\text{mm}^2$ and depth $\leq 3\text{mm}$): Fill the area with unsaturated polyester resin putty (Poly-Putty base) and then repaint following Repairing Severe Damage. - Large dent (area $> 100\text{mm}^2$ or depth $> 3\text{mm}$): Contact an local supplier for a custom repair plan.

Table 7-1: Damage assessment

7.1.3 Repairing Minor Damage

NOTE

- Tool selection: For small areas, a brush is recommended. For large areas, a spray gun is recommended for a more uniform finish.
- Paint film quality: Ensure the paint film is as thin and even as possible, without forming droplets, to maintain a smooth surface.
- Drying time: The repainted surface must stand for at least 30 minutes before any subsequent handling or operation.

Tools and Materials

- Spray paint or paint
- fine sandpaper
- anhydrous ethanol
- cotton cloth
- brush (for small areas) or spray gun (for large areas)

Procedure

1. Use fine sandpaper to polish the damaged area of the coating, removing dirt or rust.

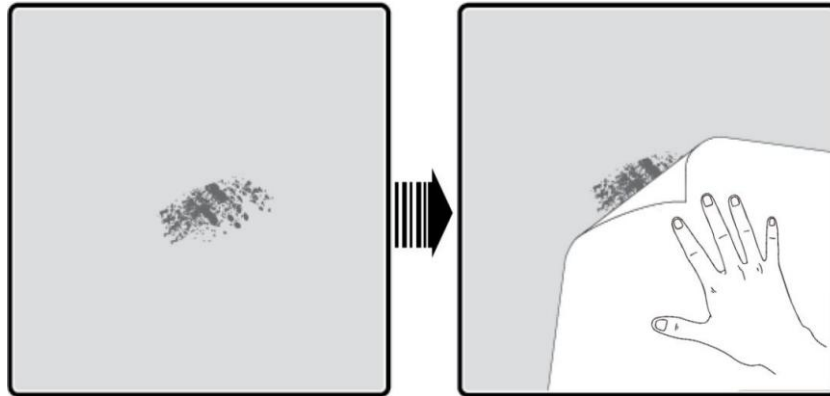

Figure 7-1: Polishing the damaged area

2. Wet a cotton cloth with anhydrous ethanol and wipe the polished or to-be-repaired area to remove surface dirt and dust, then dry it with a clean cotton cloth.

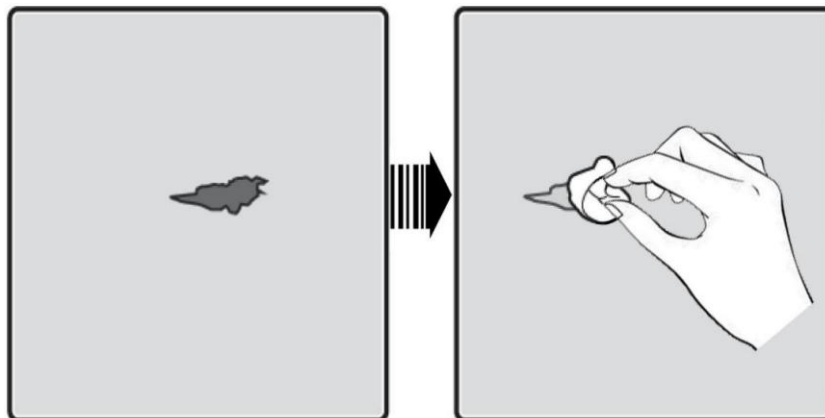

Figure 7-2: Wiping the damaged area

3. Depending on the degree of paint damage, choose one of spray paint, brush paint, or spray gun to evenly repaint the damaged area until the damage marks are not visible.

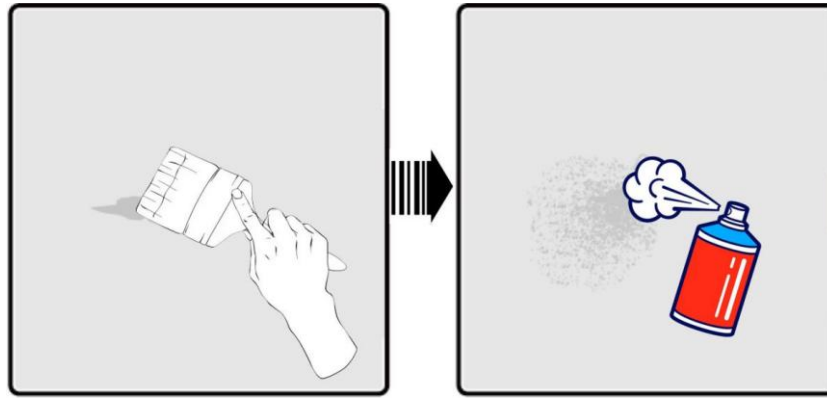

Figure 7-3: Repainting the damaged area

4. After repainting, let it stand for about 30 minutes, then check if the repainted area meets the requirements.

7.1.4 Repairing Severe Damage

NOTE

- Tool selection: For small areas, a brush is recommended. For large areas, a spray gun is recommended for a more uniform finish.
- Paint film quality: Ensure the paint film is as thin and even as possible, without forming droplets, to maintain a smooth surface.
- Drying time: The repainted surface must stand for at least 30 minutes before any subsequent handling or operation.

Tools and Materials

- Spray paint or paint
- fine sandpaper
- anhydrous ethanol
- cotton cloth
- brush (for small areas) or spray gun (for large areas)
- epoxy primer

Procedure

1. Use fine sandpaper to polish the damaged area of the coating, removing dirt or rust.

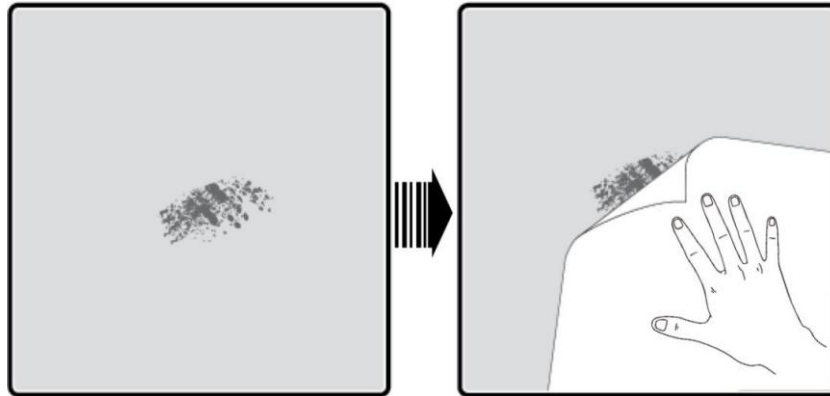

Figure 7-4: Polishing the damaged area

2. Wet a cotton cloth with anhydrous ethanol and wipe the polished or to-be-repaired area to remove surface dirt and dust, then dry it with a clean cotton cloth.

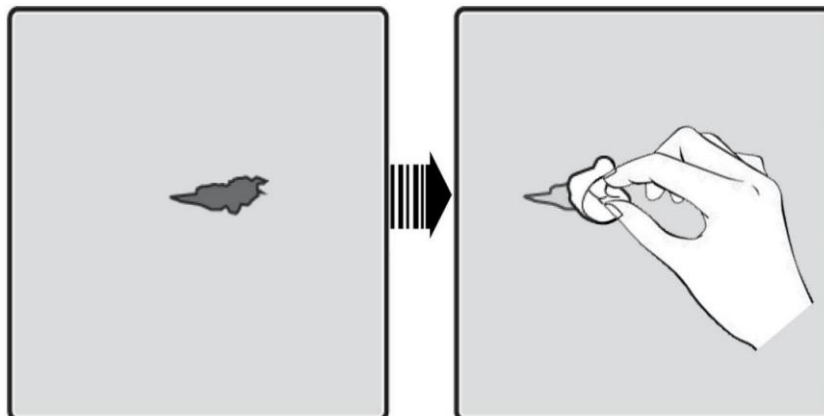

Figure 7-5: Wiping the damaged area

3. Use a brush or spray gun to apply epoxy primer to the damaged area of the coating.

NOTICE

If the to-be-repaired area exposes the substrate, the epoxy primer must be applied first. After the paint dries and does not expose the substrate, apply the polyurethane topcoat.

- Depending on the degree of paint damage, choose one of spray paint, brush paint, or spray gun to evenly repaint the damaged area until the damage marks are not visible.

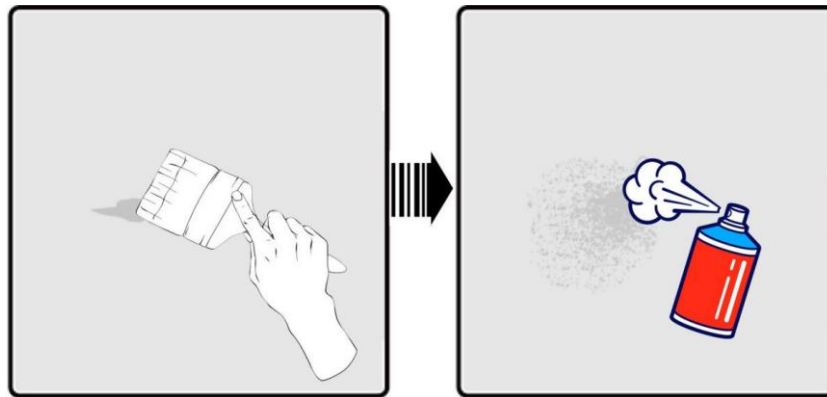

Figure 7-6: Repainting the damaged area

- After repainting, let it stand for about 30 minutes, then check if the repainted area meets the requirements.

7.1.5 Color Code

The following is a list of color codes that Teplore can provide for reference. Refer to the color sample for specifics.

Position	Color Code
Logo Red	RAL3026
Logo Black	RAL9005
Body White	RAL7035
Bottom Frame Black	RAL9005

8 Contact Information

If you have any questions about this product, please contact us.

Technical Support Email: support@teplore.com

To enable faster and more efficient service, we kindly request your assistance in providing the following information:

- Project name
- Product model
- Serial number
- Brief description of the issue